

6.10 Multi-Stage Refrigeration System:

When number of applications at same temperatures is to be taken up by the refrigerating plant, multi-stage refrigeration systems are generally used.

Assuming T_1 , T_2 , and T_3 are the refrigerating loads on evaporator E_1 , E_2 and E_3 as shown in Fig.6.10, then the refrigerant flowing through E_1 , E_2 and E_3 are given by,

$$M_1 = \frac{3.5 * T_1 * 60}{H_2 - H_1} \text{ (kg/min)}$$

$$M_2 = \frac{3.5 * T_2 * 60}{H_2 - H_1} \text{ (kg/min)}$$

$$M_3 = \frac{3.5 * 60 * T_3}{H_2 - H_1} \text{ (kg/min)}$$



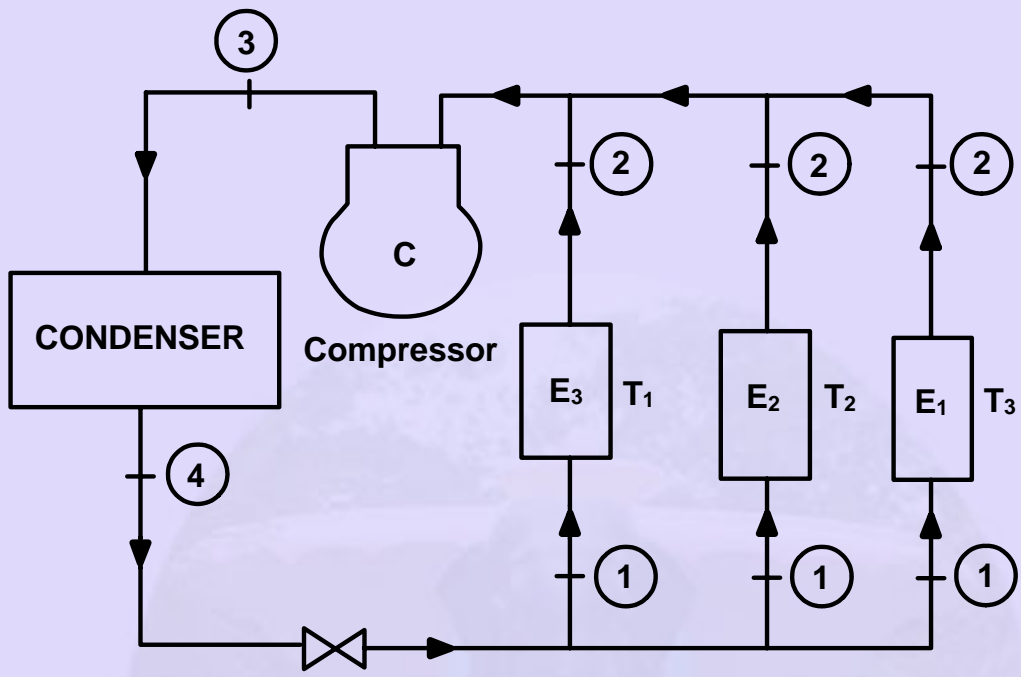

T_1, T_2 & T_3 are refrigerating loads in tons of refrigeration

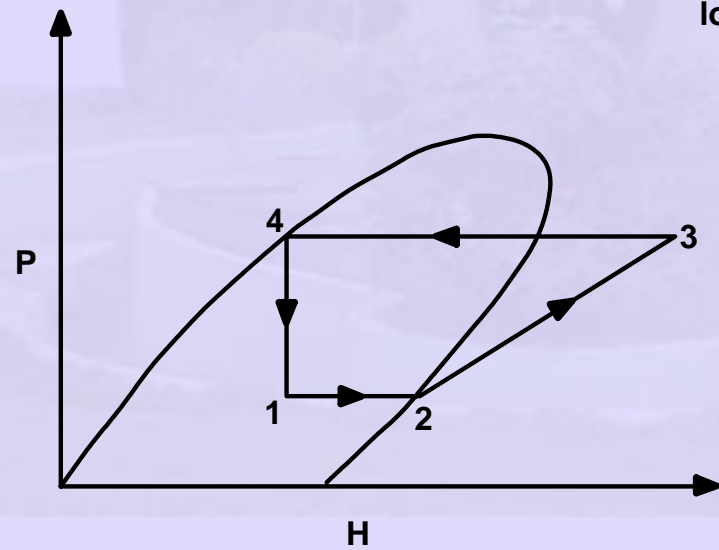

Fig.6.10. Multi-stage refrigeration system

As the temperatures in all evaporators are same, the same thermodynamic cycle will be used for all. The power required for the compressor is given by,

$$\text{Power} = \frac{(M_1 + M_2 + M_3)(H_2 - H_1)}{60} \text{ (kW)}$$

and

$$\text{COP} = \frac{H_2 - H_1}{H_3 - H_2}$$

