

## 5.8 Types of column sections

### 5.8.1 Rolled Steel Sections

Some of the sections employed as compression members are shown in Fig. 5.21. Single angles [Fig 5.21(a)] are satisfactory for bracings and for light trusses. Top chord members of roof trusses are usually made up of double angles back-to-back [Fig 5.21(b)]. The pair of angles used, has to be connected together, so they will act as one unit. Welds may be used at intervals – with a spacer bar between the connecting legs. Alternately “stitch bolts”, washers and “ring fills” are placed between the angles to keep them at the proper distance apart (e.g. to enable a gusset to be connected). Such connections are called tack connections and the terms tack welding or tacks bolting are used.

When welded roof trusses are required, there is no need for gusset plates and T sections [Fig 5.21(c)] can be employed as compression members.

Single channels or C-sections [Fig. 5.21(d)] are generally not satisfactory for use in compression, because of the low value of radius of gyration in the weak direction. They can be used if they could be supported in a suitable way in the weak direction.

Circular hollow sections [Fig. 5.21(e)] are perhaps the most efficient as they have equal values of radius of gyration about every axis. But connecting them is difficult but satisfactory methods have been evolved in recent years for their use in tall buildings.

The next best in terms of structural efficiency will be the square hollow sections (SHS) and rectangular hollow sections, [Fig. 5.21(f)] both of which are increasingly becoming popular in tall buildings, as they are easily fabricated and erected. Welded tubes of circular, rectangular or square sections are very satisfactory for use as columns in a long series of windows and as short columns in walkways and covered

warehouses. For many structural applications the weight of hollow sections required would be only 50% of that required for open profiles like I or C sections.

When the available sections are not suitable, a suitable section may be built-up either by welding or by lacing or battening two sections separated by a suitable distance.

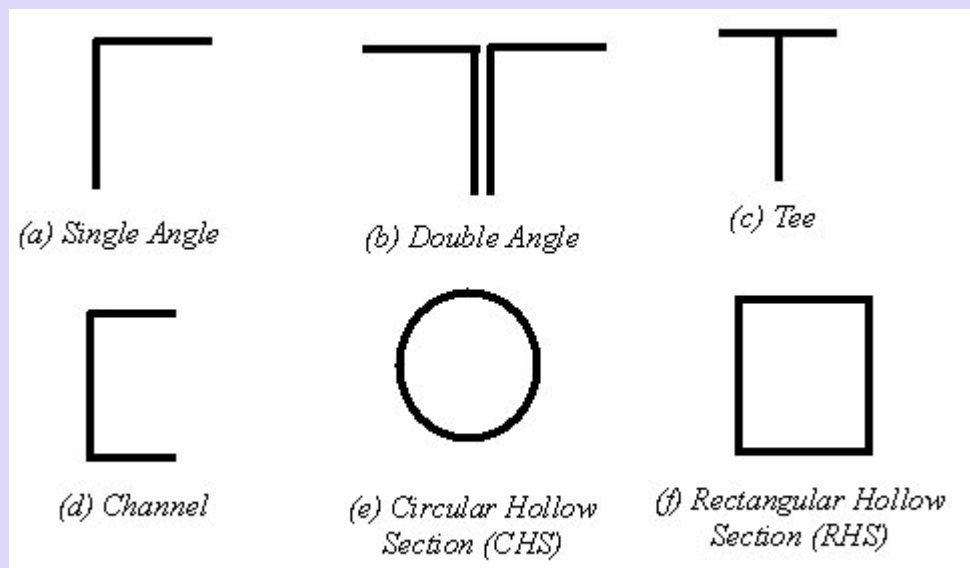

**Fig 5.21: Cross Section Shapes for Rolled Steel Compression Members**

### 5.8.2 Built-up column or fabricated compression members

Compression members composed of two angles, channels, or tees back-to-back in contact or separated by a small distance shall be connected together by tack riveting, tack bolting or tack welding so that the individual sections do not buckle between the tacks before the whole member buckles (Cl. 7.8). Special types of columns called Laced and Battened columns are discussed later in this chapter.

When compression members are required for large structures like bridges, it will be necessary to use built-up sections. They are particularly useful when loads are heavy and members are long (e.g. top chords of Bridge Trusses). Built up sections

[illustrated in Fig. 5.22(a) and 5.22(b)] are popular in India when heavy loads are encountered. The cross section consists of two channel sections connected on their open sides with some type of lacing or latticing (dotted lines) to hold the parts together and ensure that they act together as one unit. The ends of these members are connected with “batten plates” which tie the ends together. Box sections of the type shown in Fig. 5.22(a) or 5.22(b) are sometimes connected by such solid plates either at intervals (battened) or continuously along the length.

A pair of channels connected by cover plates on one side and latticing on the other is sometimes used as top chords of bridge trusses. The gussets at joints can be conveniently connected to the inside of the channels. Plated I sections or built-up I sections are used when the available rolled I sections do not have sufficient strengths to resist column loads [Fig 5.22(c)]. Flange plates or channels may be used in combination with rolled sections to enhance the load resistance of the commonly available sections, which are directly welded or bolted to each other. The lateral dimension of the column is generally chosen at around 1/10 to 1/15 of the height of the column. For purposes of detailing the connection between the flange cover plates or the outer rolled sections to the flanges of the main rolled section, it is customary to design the fasteners for a transverse shear force equal to 2.5% of the compressive load of the column. Columns with open webs may be classified as laced columns or battened columns. In Fig. 5.23, the two channel sections of the column are connected together by batten plates or laces which are shown by dotted lines. A typical lacing or batten plate is shown in Fig. 5.23

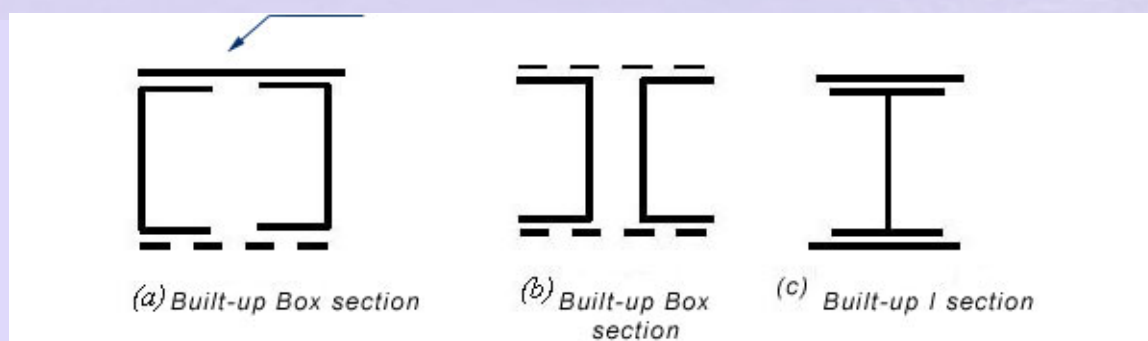

**Fig 5.22: Cross Section Shapes for Built - up or fabricated Compression Members**

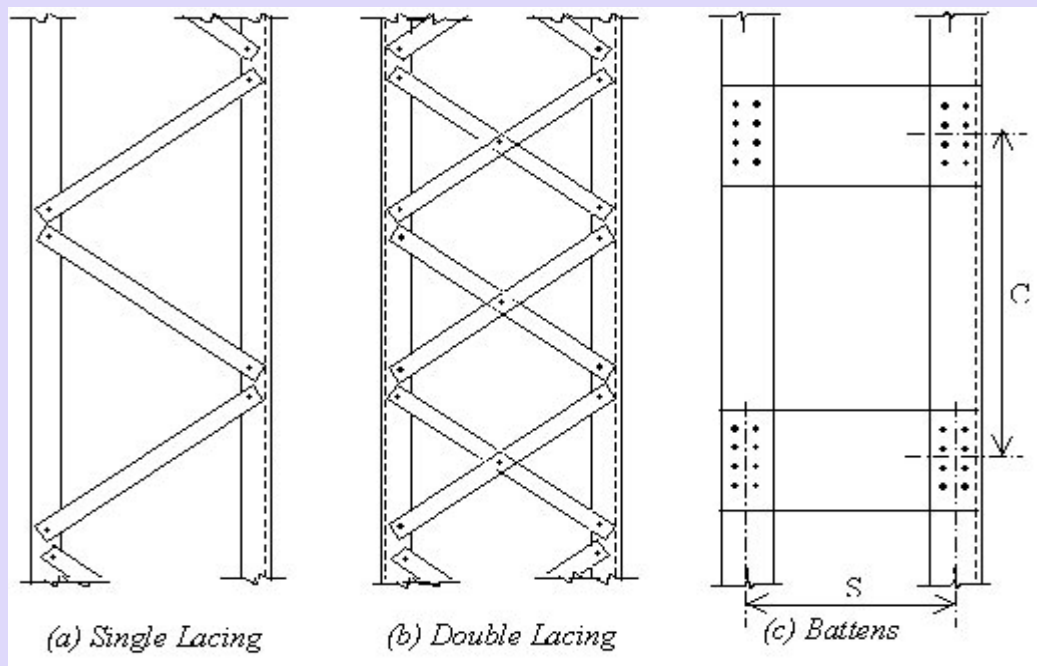

**Fig. 5.23 Built-up column members**

The Code gives simple guidelines for the design of laced (Cl.7.6) and battened columns (Cl.7.7). One of the guidelines is that such columns should where practicable, have a radius of gyration about the axis perpendicular to the plane of lacing not less than the radius of gyration about the axis parallel to the plane of lacing (Cl. 7.6.1.1). To account for the inherent flexibility of laced and battened columns, the Code suggests that the effective slenderness ratio be taken as 5 and 10% respectively more than the calculated values (Cl.7.7.1.4). All columns should be tied at the ends by tie plates or end battens to ensure a satisfactory performance.

The two channel constituents of a laced column, shown in Fig. 5.23(a) and 5.23(b) have a tendency to buckle independently. Lacing provides a tying force to ensure that the channels do not do so. The load that these tying forces cause is generally assumed to cause a shearing force equal to 2.5% of axial load on the column (Cl. 7.6.2.1). (Additionally if the columns are subjected to moments or lateral loading the lacing should be designed for the additional bending moment and shear). To prevent local buckling of unsupported lengths between the two constituent lattice points (or between two battens), the slenderness ratio of individual components should be less than 50 or 0.7 of the slenderness ratio of the built up column (whichever is less).

In laced columns, the lacing should be symmetrical in any two opposing faces to avoid torsion. Lacings and battens are not combined in the same column. The inclination of lacing bars from the axis of the column should not be less than  $40^\circ$  nor more than  $70^\circ$ . (Cl. 7.6.5) The slenderness ratio of the lacing bars should not exceed 145 (Cl. 7.6.3). The effective length of lacing bars is the length between bolts for single lacing and 0.7 of this length for double lacing. The width of the lacing bar should be at least 3 times the diameter of the bolt (Cl. 7.6.3). Thickness of lacing bars should be at least  $1/40^{\text{th}}$  of the length between bolts for single lacing and  $1/60$  of this length for double lacing (both for welded and bolted connections) (Cl. 7.6.4).

In battened columns, the Battens plates at their ends shall be riveted or welded to the main components so as to resist simultaneously a shear  $V_b = V_t C/N S$  along the column axis and a moment  $M = V_t C / 2 N$  at each connection (Cl.7.7). where,  $V_t$  = the transverse shear force;  $C$  = the distance between centre-to-centre of battens, longitudinally;  $N$  = the number of parallel planes of battens (usually 2);  $S$  = the minimum transverse distance between the centroids of the bolt group/welding connecting the batten to the main member.

When plates are used for battens, the end battens shall have an effective depth not less than the perpendicular distance between the centroids of the main members. The intermediate battens shall have an effective depth of not less than three quarters of this distance, but in no case shall the effective depth of any batten be less than twice the width of one member, in the plane of the battens. The thickness of batten or the tie plates shall be not less than one fiftieth of the distance between the innermost connecting lines of rivets or welds, perpendicular to the main member.

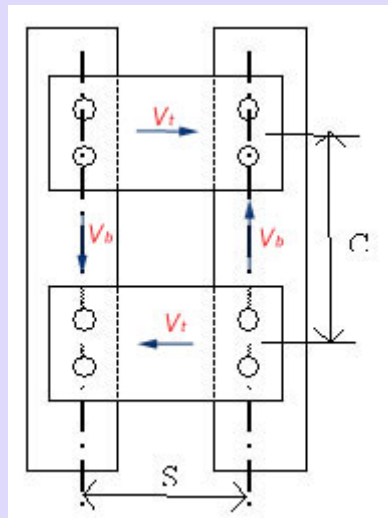

**Fig. 5.24 Battened Column**

