

## 8.5 Structural arrangement of foundation

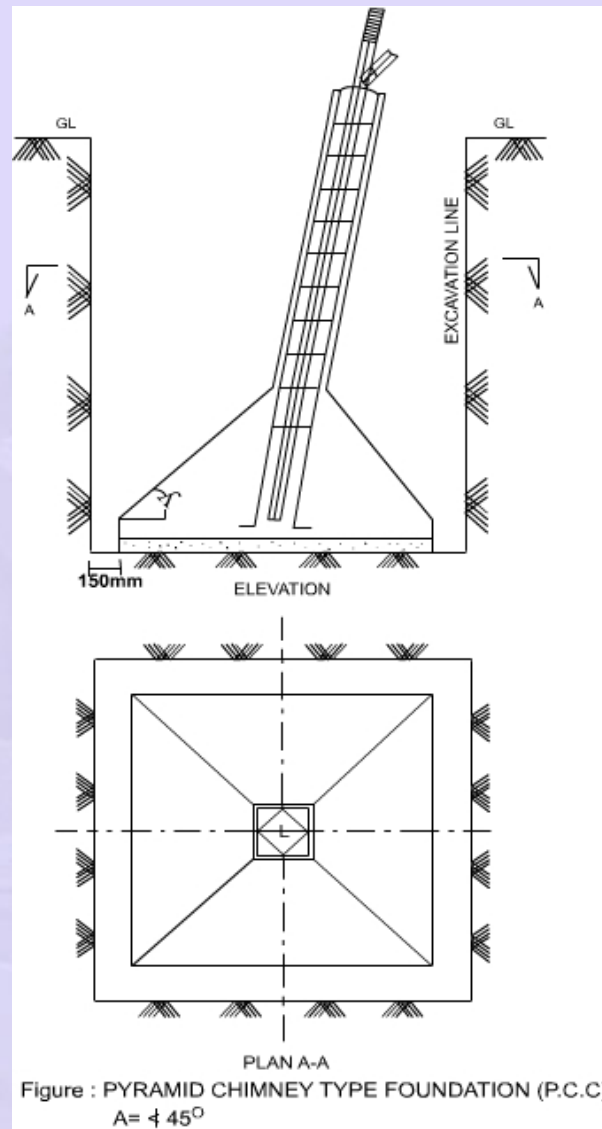
Based on structural arrangement of foundations, the various type of foundations are possible. The necessity of erecting towers on a variety of soils has made it possible and necessary for the designers to adopt new innovations and techniques. As a result, several types of tower foundations have been devised and successfully used. Some of the more common types of foundations are described below.

### P.C.C. types

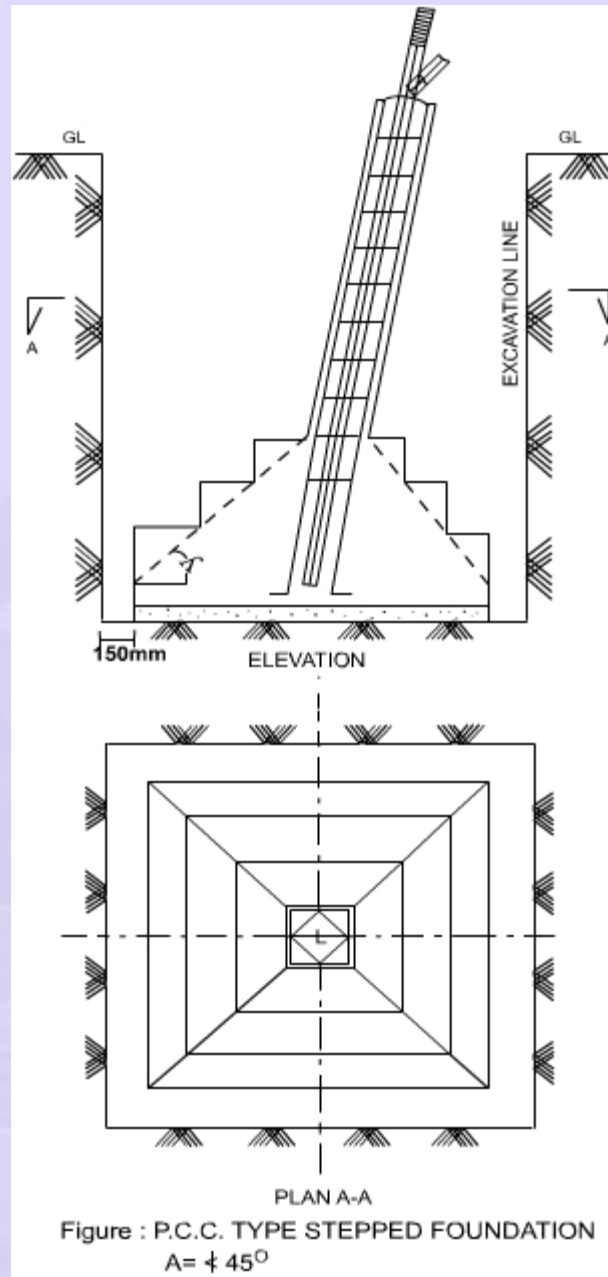
This type of foundation consists of a plain concrete footing pad with reinforced chimney. They is as shown in figure. In this type of foundation, the stub angle is taken inside and effectively anchored to the bottom pad by cleat angles and / or keying rods and the chimney with reinforcement and stub angle inside works as a composite member. The pad may be either pyramidal in shape as shown in Figure 8.1(a) or stepped as shown in Figure 8.1(b). Stepped footings will require less shuttering materials but need more attention during construction to avoid cold joints between the steps. The pyramidal footings on the other hand will require somewhat costlier formwork. In this pad and chimney type footing, where the chimney is comparatively slender, the lateral load acting at the top of the chimney will cause bending moment and, therefore the chimney should be checked for combined stress due to direct pull / thrust and bending.

If the soil is very hard, conglomerate of soil, containing stones, rubbles, kankar which can be loosened with the help of pick-axe or if the soil is of composite nature i.e. combination of normal dry soil, hard murrum, fissured rock which will not get unified easily with the parent soil after back filling, pyramid chimney type foundations having 150m side clearance are not advisable and in

such cases undercut / stepped footings without side clearance should be adopted.



**Figure 8.1(a)**



**Figure 8.1(b)**

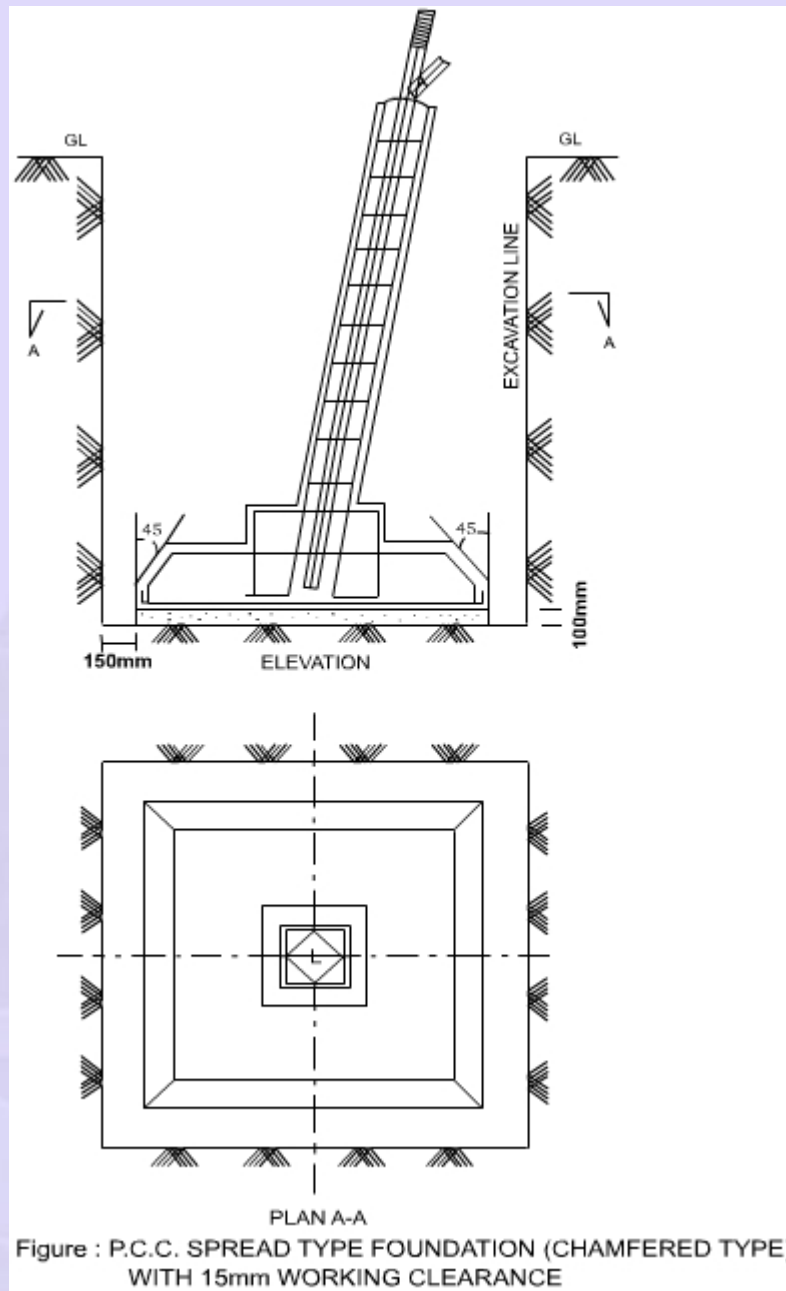
## R.C.C. spread type

Typical types of R.C.C spread footings are shown in figure 8.2. It consists of a R.C.C base slab or mat and requires a square chimney.

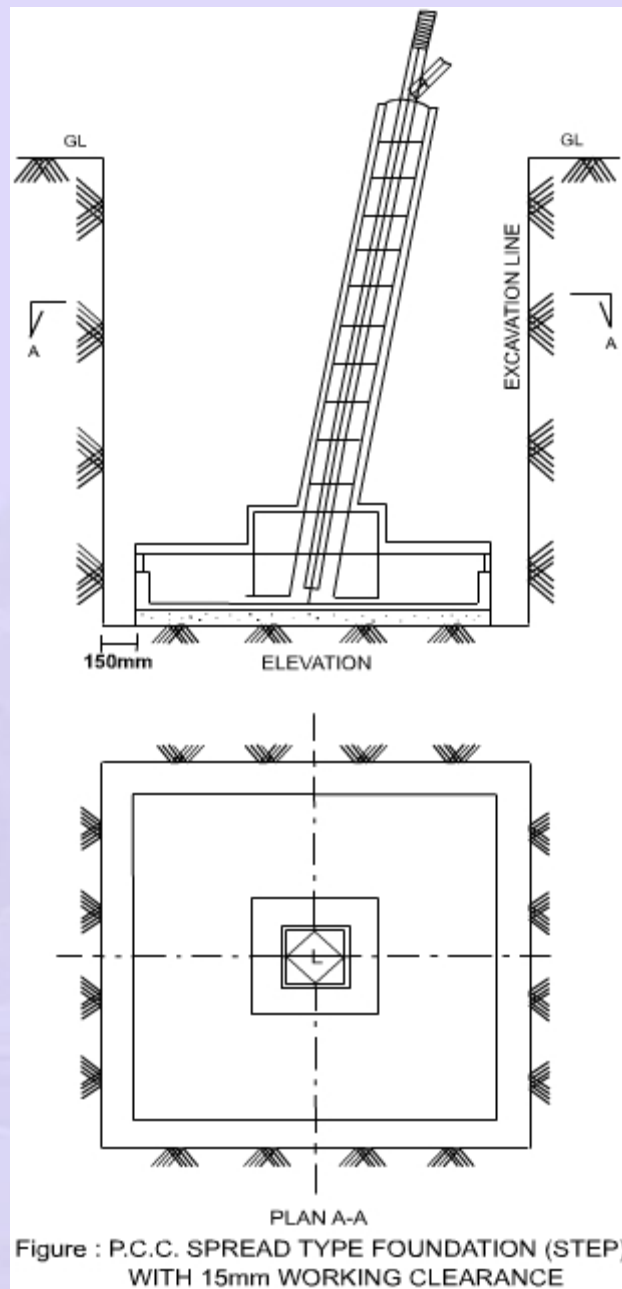
There are several types of R.C.C spread footings which can be designed for tower foundations. The three most common types of these are shown in figure 8.2(a), (b) and (c). As shown in figures, this type of foundation can be either single step type or multiple step type and / or chamfered step type.

The R.C.C spread type footing can be suitably designed for variety of soil conditions. R.C.C footings in some situations may be higher in cost although structurally these are the best.





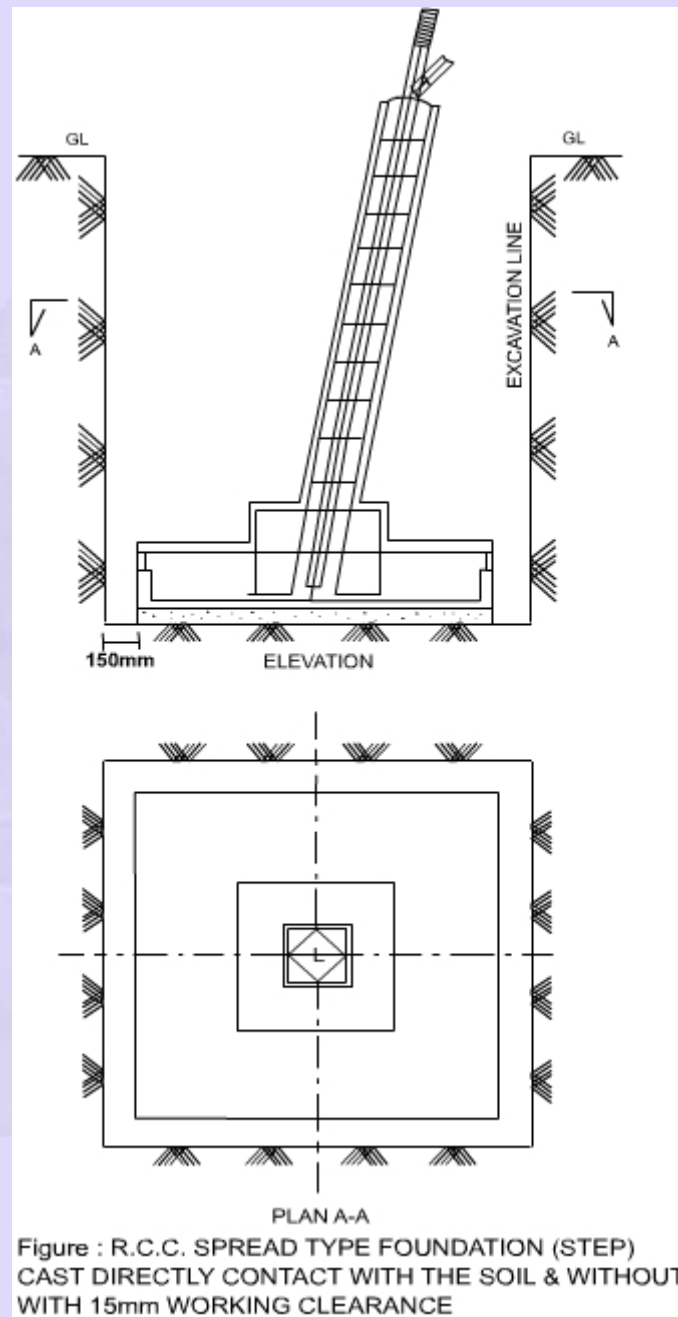
**Figure 8.2(a)**



**Figure 8.2(b)**

When loads on foundations are heavy and / or soil is poor, the pyramid type foundations may not be feasible from techno-economical considerations and under such situations, R.C.C spread type footings are technically superior and also economical. R.C.C spread footing with bottom step/slab when cast in

contact with inner surface of excavated soil will offer higher uplift resistance as compared to the footing having 150mm side clearance as shown in figure 8.2(c)



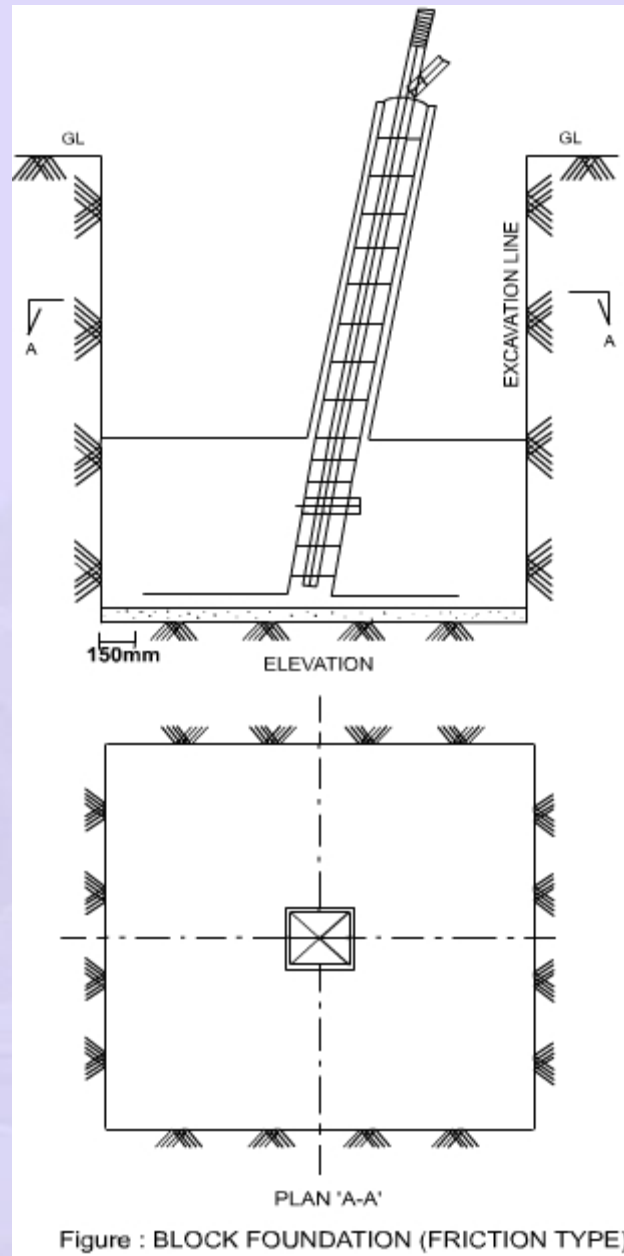
**Figure 8.2 (c)**

## Block type

This type of foundation is shown in fig 8.3 and fig 8.5(a). It consists of a chimney and block of concrete. This type of foundation is usually provided where soft rock and hard rock strata are encountered at the tower location. In this type of foundation, concrete is poured in direct contact with the inner surfaces of the excavated rock so that concrete develops bond with rock. The bond between concrete and rock provides the uplift resistance in this type of footing. The thickness and size of the block is decided based on uplift capacity of foundation and bearing area required.

It is advisable to have footing with a minimum depth of about 1.5m below ground level and check this foundation for the failure of bond between rock and concrete. The values of ultimate bond stress between the rock and the concrete to be considered for various types of rocks are given in Table 8.2 of Annexure for guidance. However, the actual bond stress between rock and concrete can be decided by tests.

Block type foundations are being provided by some power utilities for soft and hard rock strata. However, under cut type of foundations for soft rock and rock anchor type of foundations for hard rock are sometimes preferred by some power utilities because of their soundness though these are more costly in comparison with Block type foundations.

**Figure 8.3**

**Table: 8.2 Bond stress as per IS: 456-2000**

(1) Limit bond stress between concrete and reinforcement steel deformed in tension of grade Fe415 (conforming to IS:1786-1985 and 1139-1165)	
(a) With M15 Mix	16.0 kg/cm <sup>2</sup>
(b) With M 20 Mix	19.5 kg/cm <sup>2</sup>
Note: For bars in compression the above values shall be increased by 25%	
(2) Limit bond stress between concrete and stubs in tension with	
(a) M15 Mix	10.0 kg/cm <sup>2</sup>
(b) M20 Mix	12.0 kg/cm <sup>2</sup>
For compression above values will be increased by 25%	
(3) Limit bond stress between rock and concrete	
(a) In Fissured rock	1.5 kg/cm <sup>2</sup>
(b) In Hard rock	4.0 kg/cm <sup>2</sup>
(4) Limit bond stress between hard rock and grout	2.0 kg/cm <sup>2</sup>

### Under cut type

These types of foundations are shown in figures 8.4(a), (b), (c). These are constructed by making under-cut in soil / rock at foundation level. This type of foundation is very useful in normal dry cohesive soil, hard murrum, fissured / soft rock, soils mixed with clinker, where soil is not collapsible type i.e. it can understand by itself. A footing with an under-cut generally develops higher uplift resistance compared to that of an identical footing without under-cut. This is due to hte anchorage in un disturbed virgin soil. The size of under-cut shall not be less than 1.50mm. At the discretion of utility and based on the cohesiveness of the normal dry soil, the owner may permit undercut type of foundation for normal and cohesive soil.

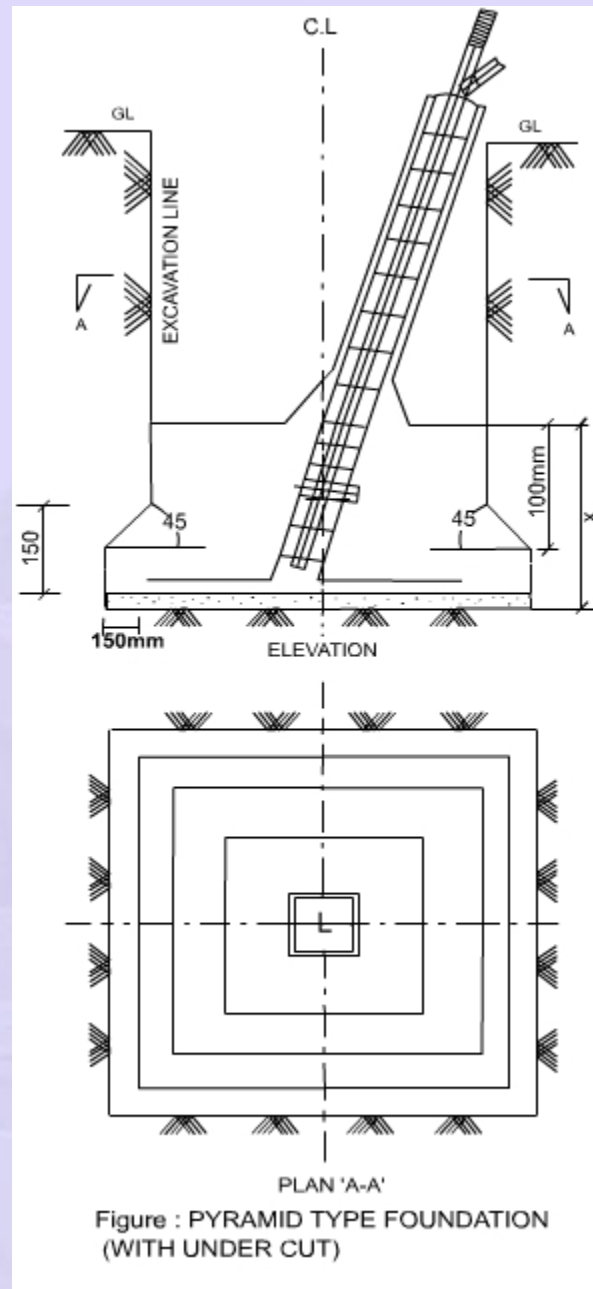


Figure 8.4(a)

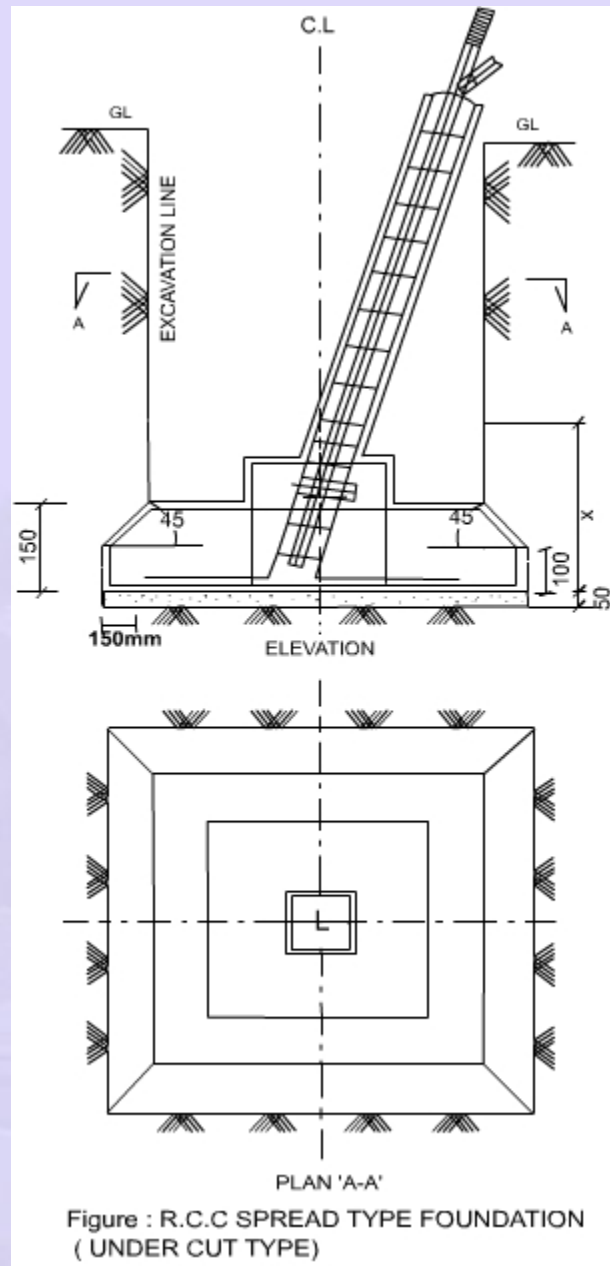


Figure 8.4(b)

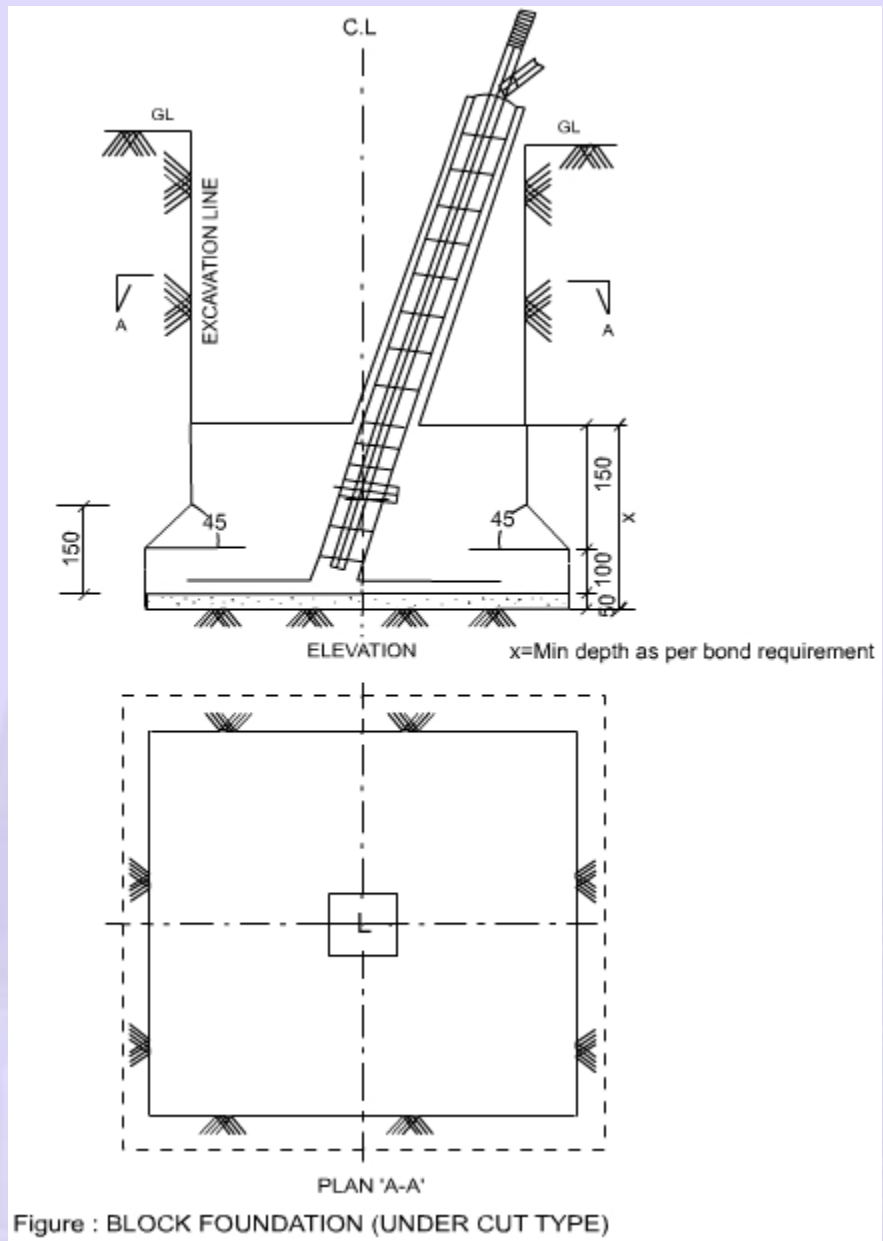


Figure : BLOCK FOUNDATION (UNDER CUT TYPE)

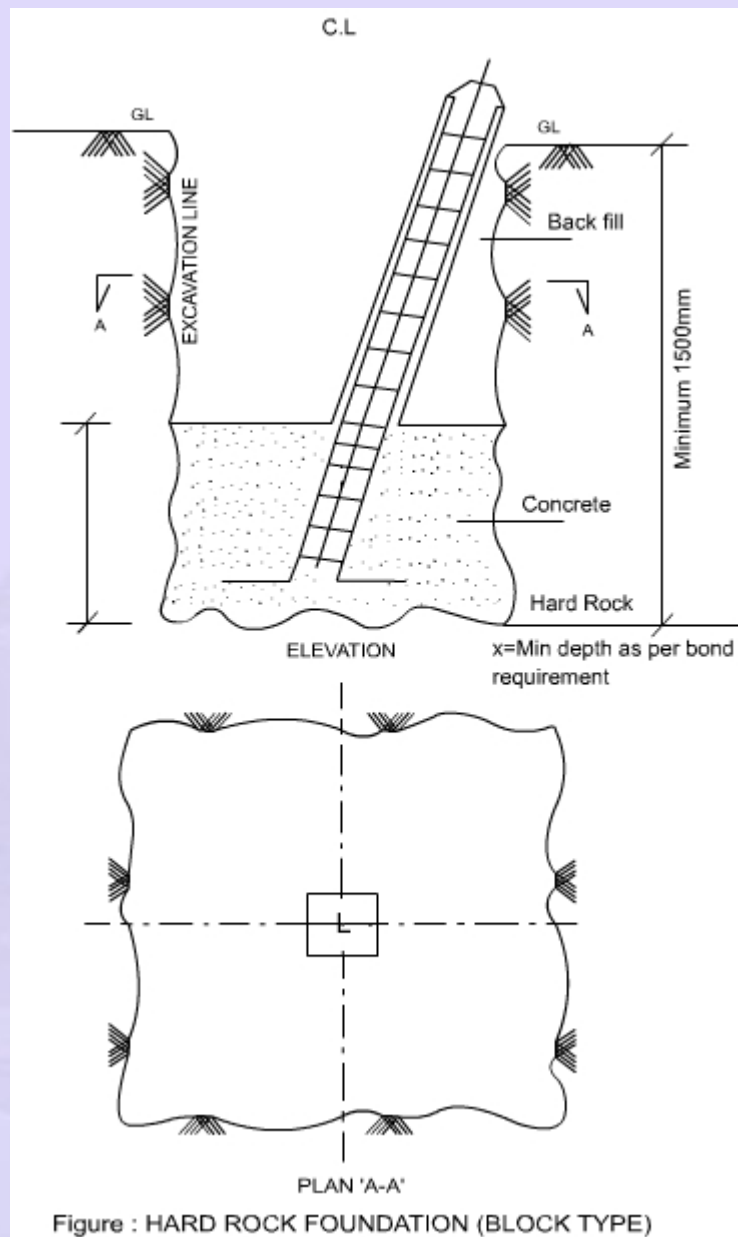
Figure 8.4(c)

## Grouted rock and Rock anchor type

Typical Grouted rock and Rock anchor type footing is shown in figure 8.5(b). This type of footing is suitable when the rock is very hard. It consists of two parts viz., Block of small depth followed by anchor bars embedded in the grouted anchor holes. The top part of the bar is embedded in the concrete of the shallow block. The depth of embedment, diameter and number of anchor bars will depend upon the uplift force on the footing. The diameter shall not be less than 12mm. The grouting hole shall normally be 20mm more than diameter of the bar.

The determination of whether a rock formation is suitable for installation of rock anchors is an engineering judgement based on rock quality. Since, the bearing capacity of rock is usually much greater, care must be exercised in designing for uplift. The rock surfaces may be roughened grooved or shaped to increase the uplift capacity.

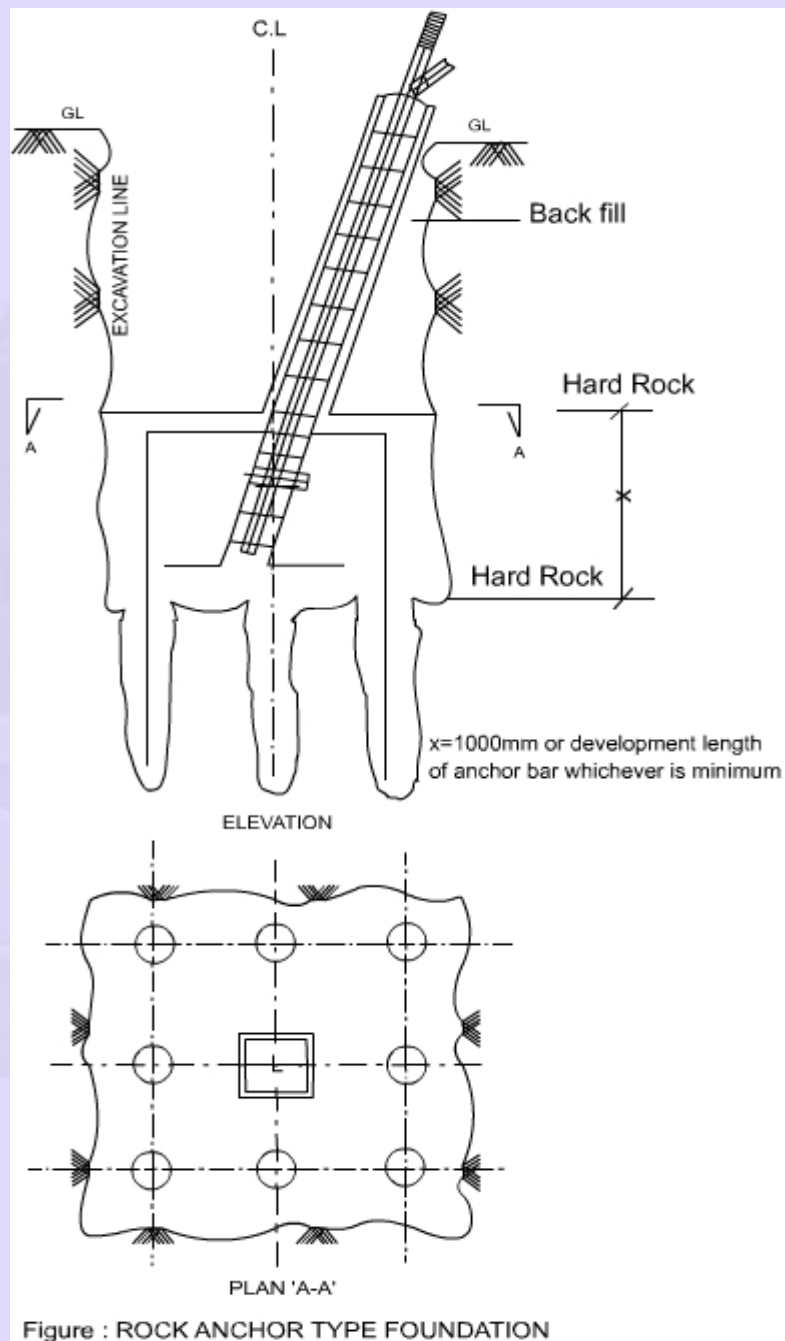




**Figure 8.5(a)**

The uplift resistance will be determined by considering the bond reinforcement bar and grout / concrete. However, an independent check for uplift resistance should be carried out by considering the bond between rock and concrete block which in turn will determine the minimum depth of concrete block to be provided in hard rock. Anchor strength can be substantially increased by

provision of mechanical anchorages, such as use of eye-bolt, fox bolt, or threaded rods as anchoring bars or use of keying rods in case of stub angle anchoring. The effective anchoring strength should preferably be determined by testing.

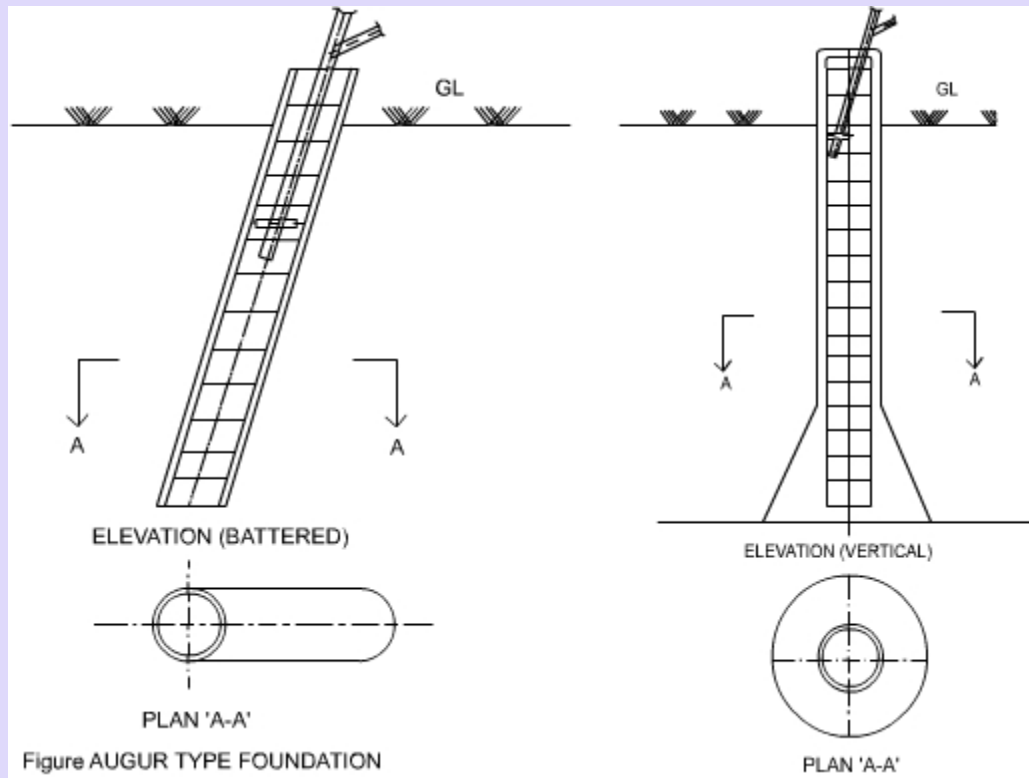


**Figure 8.5(b)**

## Augur type / under-reamed pile type

Typical types of foundation are shown in figure 8.6(a). The cast-in-situ reinforced concrete augured footings have been extensively used in some western countries like USA, Canada and many Asian countries. The primary benefits derived from this type of foundations are the saving in time and manpower. Usually a truck mounted power augur is utilized to drill a circular hole of required diameter, the lower portion of this may be belled, if required, to a larger diameter to increase the uplift resistance of the footing. Holes can be drilled up to one meter in diameter and six meter deep. Since, the excavated hole has to stand for some time before reinforcing bars and cage can be placed in position and concrete poured. Usually, stiff clays and dense sands are capable of being drilled and standing up sufficiently long for concreting works and installation of stub angle or anchor bolts, whereas loose granular materials may give trouble during construction of these footings. Bentonite slurry or similar material is used to stabilize the drilled hole. In soft soils, a steel casing can also be lowered into the hole as the excavation proceeds to hold the hole open.

The friction along the surface of the shaft alone provides uplift resistance of augured footing without bell and hence its capacity to resist uplift is limited. Augured footing can be constructed according to the requirements, vertical or battered and with or without expanded base.



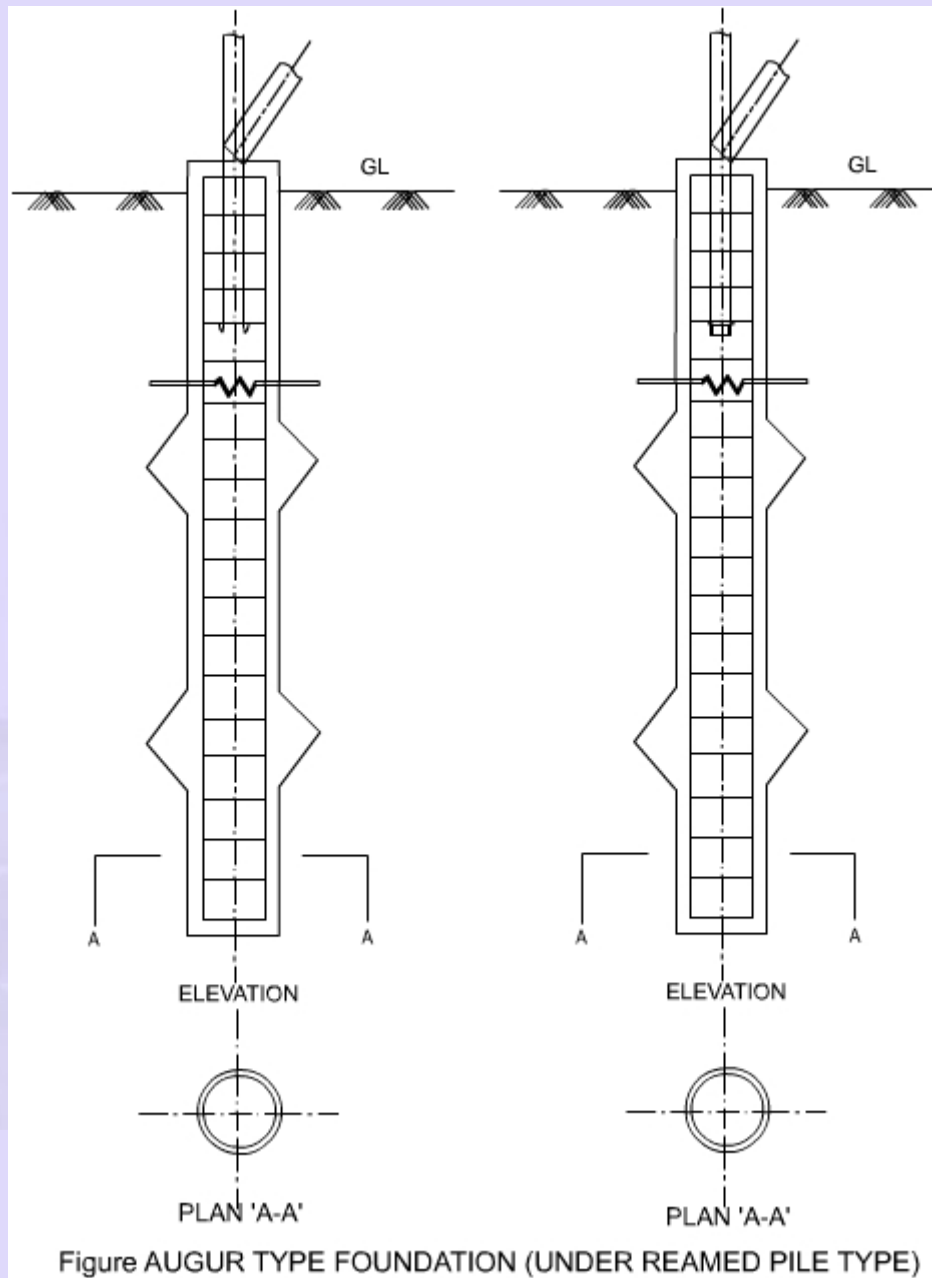
**Figure 8.6(a)**

### **Under-reamed pile type**

The under-reamed piles are more or less similar to augured footings except that they have under reaming above bottom of shaft. These can be generally constructed with hand augur. The bore is drilled vertically or at a batter with the augur, having an arrangement of cutting flanges (edges) to be opened by the lever. This arrangement makes it possible to make under-reams at various levels of bores as shown in fig 8.6(b). The advantage of this foundation is faster construction.

The load carrying capacity of these footings, both for downward and uplift forces should be established by tests. The safe loads allowed on under-reamed piles of length 3.50m and under-reamed to 2.5 times shaft diameter in clayey,

black cotton and medium dense sandy soils may be taken from IS: 4091 for guidance.

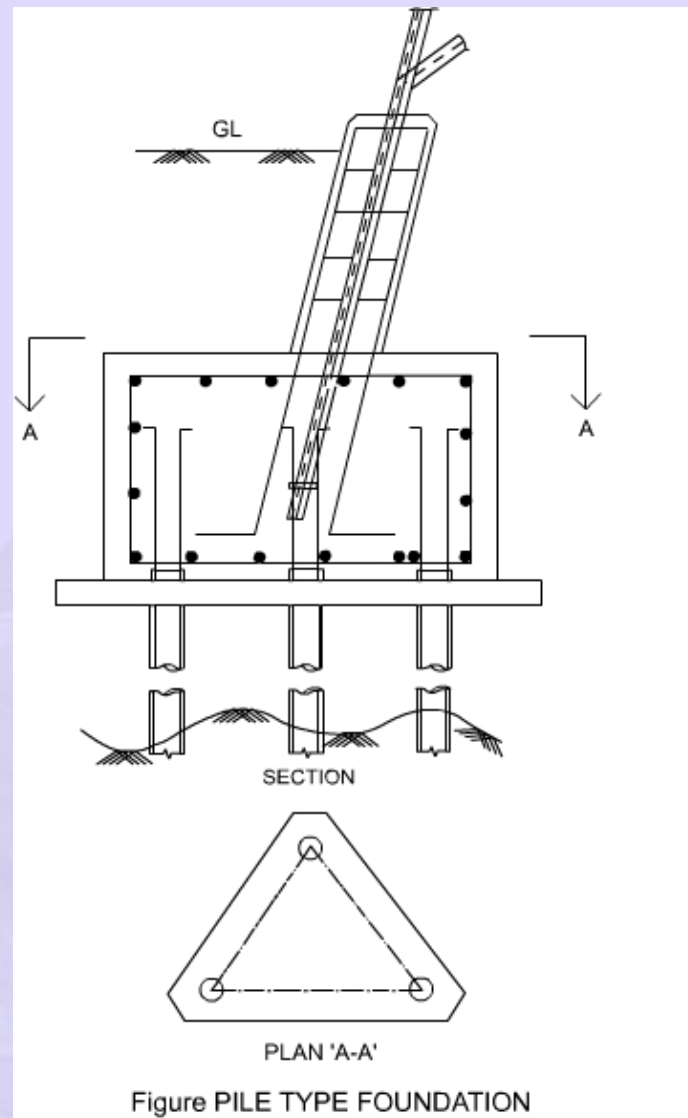


**Figure 8.6(b)**

## Pile type

A typical pile type is shown in Figure 8.7. This type of foundation is usually adopted when soil is very weak and has very poor bearing capacity or foundation has to be located in filled-up soil or sea mud to a large depth or where tower location falls within river bed and creek bed which are likely to get scoured during floods. The pile foundations are designed based on the data of soil exploration at the tower location. The important parameter for the design of pile foundation the type of soil, angle of internal friction, cohesion and unit weight of soil at various depths along the shaft of pile, maximum discharge of the river, maximum velocity of water, high flood level, scour depth etc.

Pile foundation usually costs more and may be adopted only after the detailed examination of the site condition and soil data. The downward vertical load on the foundation is carried by the dead weight of the concrete in piles and pile caps and frictional resistance between pile and soil surrounding the pile. For carrying heavy lateral loads, battered piles may be advantageously used. Piles are of different types such as driven pre-cast piles, cast-in-situ concrete bored piles and cast-in-situ concrete driven piles, concrete driven piles whether pre-cast or cast-in-situ, require heavy machinery for their construction and as such may not be possible to use for transmission line foundations because of the remoteness of the sites and small volume of work. Mostly, cast-in-situ concrete bored piles are provided in transmission line projects since, they do not require heavy machinery for their construction.



**Figure 8.7**