

## 6 Phasor diagrams

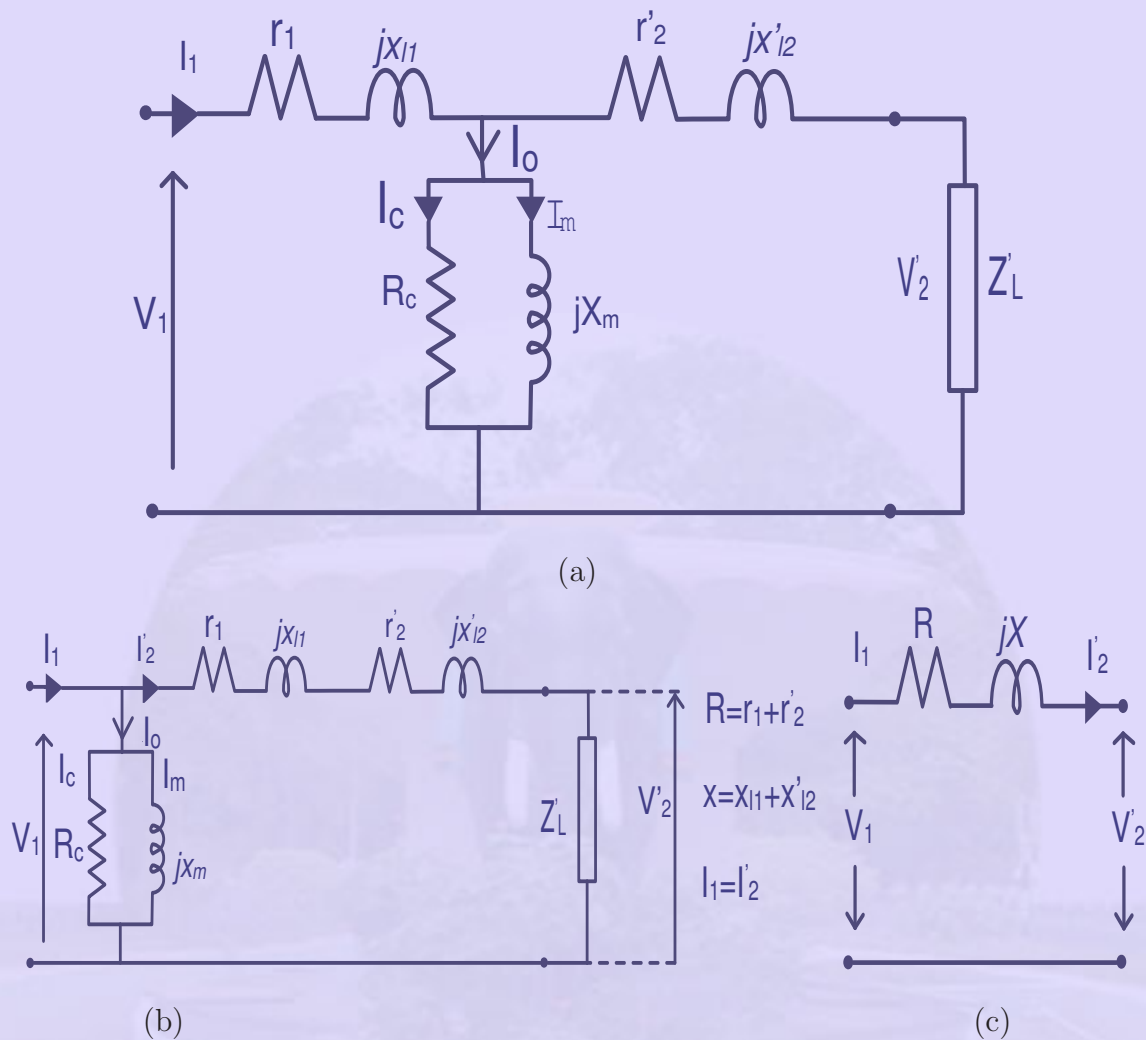

Figure 16: Exact, approximate and simplified equivalent circuits

The resulting equivalent circuit as shown in Fig. 16 is known as the exact equivalent circuit. This circuit can be used for the analysis of the behavior of the transformers. As the no-load current is less than 1% of the load current a simplified circuit known as ‘approximate’ equivalent circuit (see Fig. 16(b)) is usually used, which may be further

simplified to the one shown in Fig. 16(c).

On similar lines to the ideal transformer the phasor diagram of operation can be drawn for a practical transformer also. The positions of the current and induced emf phasor are not known uniquely if we start from the phasor  $V_1$ . Hence it is assumed that the phasor  $\phi$  is known. The  $E_1$  and  $E_2$  phasor are then uniquely known. Now, the magnetizing and loss components of the currents can be easily represented. Once  $I_0$  is known, the drop that takes place in the primary resistance and series reactance can be obtained which when added to  $E_1$  gives uniquely the position of  $V_1$  which satisfies all other parameters. This is represented in Fig. 17(a) as phasor diagram on no-load.

Next we proceed to draw the phasor diagram corresponding to a loaded transformer. The position of the  $E_2$  vector is known from the flux phasor. Magnitude of  $I_2$  and the load power factor angle  $\theta_2$  are assumed to be known. But the angle  $\theta_2$  is defined with respect to the terminal voltage  $V_2$  and not  $E_2$ . By trial and error the position of  $I_2$  and  $V_2$  are determined.  $V_2$  should also satisfy the Kirchoff's equation for the secondary. Rest of the construction of the phasor diagram then becomes routine. The equivalent primary current  $I_2'$  is added vectorially to  $I_0$  to yield  $I_1$ .  $I_1(r_1 + jx_{l1})$  is added to  $E_1$  to yield  $V_1$ . This is shown in fig. 17(b) as phasor diagram for a loaded transformer.

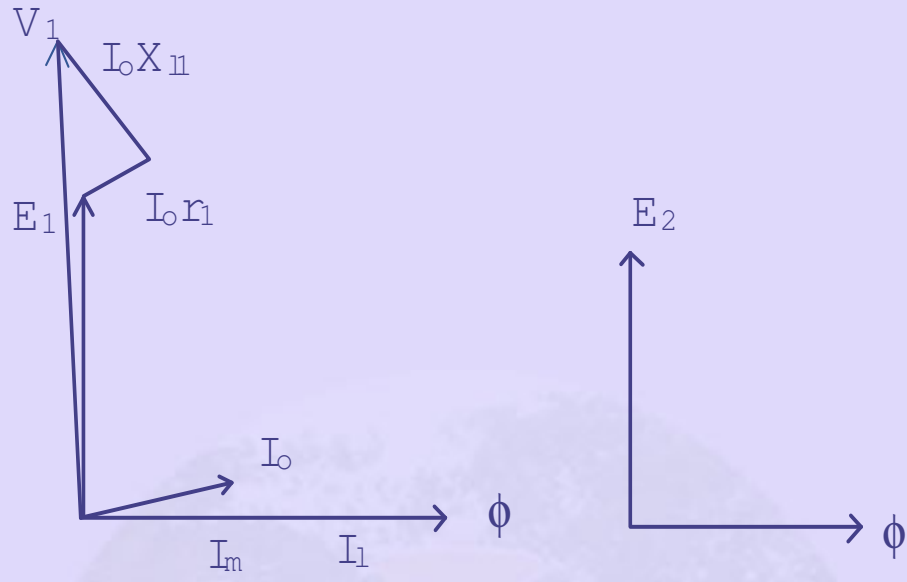

(a) No-load

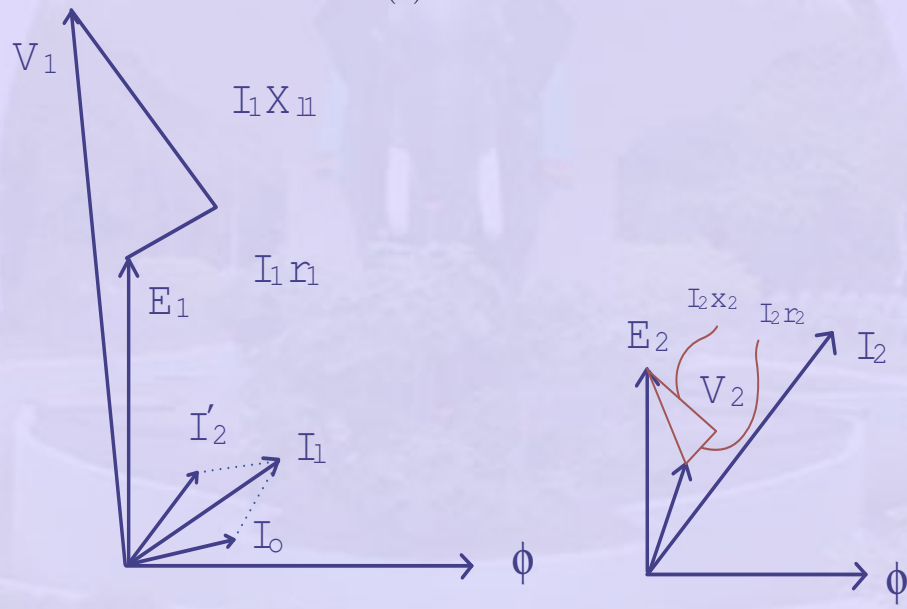

(b) On-load

Figure 17: Phasor Diagram of a Practical Transformer