

MODULE 4.3

Atmospheric analysis of particulates

Measurement And Characterisation Of The Particulate Content	1
Total particulate concentration	1
Composition of the particulate	1
Determination of particle size distribution	2
Sampling methods	2
High-volume samplers	2
Personal samplers	4
Cascade impactors	4
Determination of total organic content in the gas sample	6
Analysis of particulates after dissolution	6
Metals	6
Organic compounds	7
Direct Analysis Of Particulates	7
X-ray fluorescence	7
X-ray Emission by fast electron	8
Neutron activation analysis	9
Infrared spectrometry	10
Drawbacks of the direct analysis	10

MODULE 4.3

Atmospheric analysis of particulates

In this section sampling and analysis of atmospheric particulate materials are discussed. The analytical methods are divided into those requiring sampling dissolution prior to analysis and those which can analyse solid material directly without a dissolution stage. The solid phase analytical techniques are briefly described first and the analytical methods involving dissolution are discussed later.

Measurement And Characterisation Of The Particulate

Content:

1. Total particulate concentration: It is a measurement of the mass of solid extracted from a fixed volume of atmosphere by filtration or by other methods. Typical analytical values are:

70 $\mu\text{g m}^{-3}$ in rural air

300 $\mu\text{g m}^{-3}$ in urban air

1 mg m^{-3} in factory workshop

100 mg m^{-3} in power station flue gases

2. Composition of the particulate: This involves elemental analysis particularly for metals. Since the inorganic component of the particulate material may be present as insoluble silicate salts two approaches are possible for the analysis of these particulates. Extreme conditions may be used to dissolve the

sample, followed by the determination of metals by the methods that are discussed in chapter 2.4. Alternatively other techniques can be used which do not require sample dissolution.

3. Determination of particle size distribution: Particle size determination is important because of the following reasons. (a) The resident time of a particle in the atmosphere is dependent on its size. The smaller the particle size, the greater is the resident time. (b) Particles with $< 5\mu\text{m}$ size have the greatest potential physiological effect and this fraction of particulate matter is called 'respirable' dust. (c) The study of the emissions from a particular industrial processes reveals that the particulate matter is often within a narrow size range.

Sampling methods:

Since the concentrations of particulates vary rapidly with time and location, careful sample strategies have to be adopted in particulate sampling. In internal atmospheres there is often a measurable vertical variation even over a few centimeters. Hence emphasis is laid on personal sampling to assess the exposure of an individual rather than comprehensive survey of background levels. However for external atmospheres background concentration using large-through put (high-volume) samplers remains the most appropriate method.

High-volume samplers:

The high volume sampler is the most popular method of measurement of the mass concentration of suspended particulates smaller than $10\mu\text{m}$. The sampler is illustrated in fig.1.

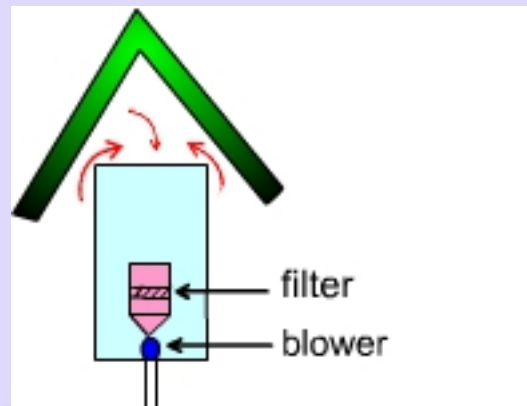

Fig.1 High volume sampler

In this method, a known volume of air is sucked by a high speed blower through a fine filter and increase in weight due to the trapped particles is measured. The filter has a large diameter (20-25 cm) and should be compatible with the subsequent analytical procedure. Some procedures require the total combustion of the filter, others its dissolution. Cellulose filters are used for the analysis of metals and inorganic anions and glass-fibre filters for most of the organics. The filter provides a dense porous medium through which an air stream must change direction in random fashion, allowing the entrained particles to impact on the filter material. A typical glass fibre filter used in the air samplers has an efficiency of over 99 percent for particles of size $0.3\ \mu\text{m}$ and it is moderately effective for trapping particles of as small size as $0.05\ \mu\text{m}$. Typical sampling times range from 1h for contaminated urban atmospheres to 24h for clean rural atmospheres. During this time over 2000m^3 of air would have been sucked through the filter. The analysis is gravimetric and the particulate level is generally expressed in terms of μgm^{-3} of air. Based on typical results of such sampling, the following example would illustrate the calculation.

Air flow through the clean filter = $1.6\ \text{m}^3\text{min}^{-1}$

Air flow through the filter at the end of collection = $1.4 \text{ m}^3 \text{ min}^{-1}$

Average air flow = $1.5 \text{ m}^3 \text{ min}^{-1} = 2160 \text{ m}^3$ in 24 hrs

Weight of clean filter = 4.854 g

Weight of filter after exposure = 5.178 g

Weight of particulate dust = 0.324 g = $0.324 \times 10^6 \mu\text{g}$

$$\begin{aligned} \text{Suspended particulate concentration} &= \frac{0.324 \times 10^6 \mu\text{g}}{2160 \text{ m}^3} \\ &= 150 \mu\text{g m}^{-3} \end{aligned}$$

Personal samplers

Personal samplers have filter holder clipped to lapel and pump around the waist. The pump is similar in design to those used for organic gas sampling described previously with one difference—dust sampling is at the higher rate of approximately 2 l min^{-1} through a 25 mm filter. Filters are glass-fibre if simply a total particulate mass is required. For elemental analyses, depending on the subsequent analytical procedure other filter material may be used. This apparatus will produce a representative sample of total inhalable (inspirable) dust.

Cascade impactors

In the previous high volume sampling method particulate materials are collected by filtration. It gives only the total particulate content in an air sample. Cascade impactors on the other hand can be used to determine particle size distribution in an air sample. They rely on adhesion of particulates on a surface.

In this method particulates are fractionated according to their mass. A typical apparatus is shown in fig.2.

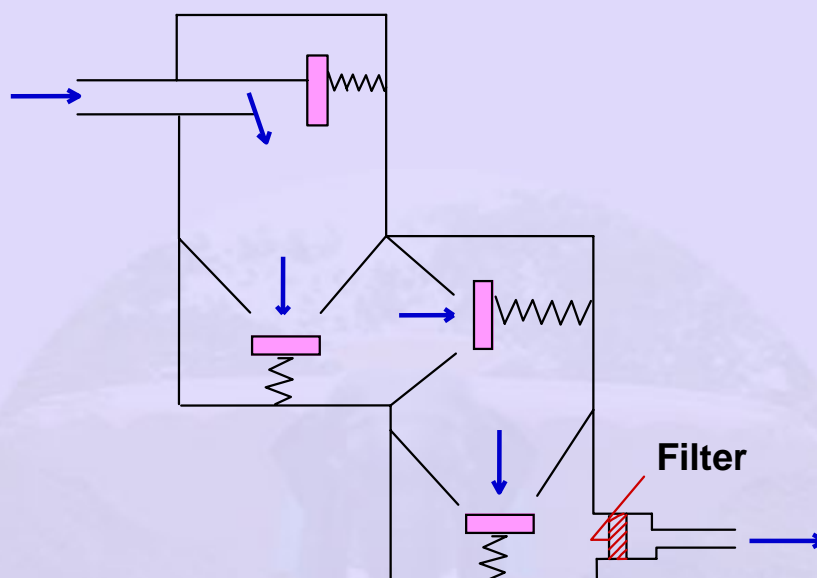

Fig 2 Four stage cascade impactor

The cascade impactor consists of 5 to 10 collection stages in which the sample air stream is constrained to pass through a series of jets where pollutant particles are directed against collection surfaces placed normal to the jets. Smaller particles having lower momentum, are collected in later stages, where the jet velocities become progressively higher. In most cascade impactors a filter is placed after the last stage to collect any fine particles that might have passed through the impactor. After sampling, the material collected at each stage is analysed for its weight and chemical composition. The impactors are reported to be capable of sizing particles down to $0.2 \mu\text{m}$, and an efficiency of 100 percent for particles as small as $0.6 \mu\text{m}$ has been obtained.

Determination of total organic content in the gas sample:

If the total organic content of the atmosphere were to be determined in the gas sample, it has to accommodate both solid and vapour phases. After passing through a filter to remove particulates, the gas is then drawn through an adsorbent (activated charcoal or Tenax porous polymer) to extract the vapour phase component. The analysis of the two phases can then be done separately.

Analysis of particulates after dissolution:

Metals:

The important step for a particulate analysis is the correct choice of dissolution method. If the composition of the sample is unknown, hydrofluoric acid, which is capable of dissolving silicates, may be used. Teflon apparatus is required and the analyses should be performed in a hydrogen fluoride-resistant fume cup-board. This procedure solubilises the filter in addition to the sample.

If the composition of the dust sample is known dissolution may be achieved with dilute acid, mild oxidising agents or even water. In this procedure the filter paper remains undissolved.

Once the sample has been dissolved, the analysis can be done by a number of methods available for metal ions in solution such as atomic absorption or uv / visible absorption spectrometry.

For less routine analysis and particularly for the analysis of metals at low concentration, inductively coupled plasma optical emission, inductively coupled plasma mass spectrometric, flame atomic emission, and atomic fluorescence

techniques can be used. The only difficulty is that the sensitivity of each technique is different for each element.

Organic compounds:

Simple determination of organic content may be by analysis of total organic carbon (as described under water analysis) or by mass loss after extraction-with an organic solvent. The components of the extract can then be determined by the spectrometric and chromatographic method, as described earlier.

Direct Analysis Of Particulates:

Four representative techniques are briefly discussed in this chapter of which the first three are methods for elemental analysis using equipment which will be available only in specialist laboratories.

X-ray fluorescence:

This technique is based on the irradiation of a target atom with high-energy X-radiation leading to the ejection of an electron from an inner shell. Outer shell electrons cascade to the inner shell to fill the vacancy, emitting X-rays. The wavelength of this radiation is related to the atomic number of the nucleus according to the equation

$$1/\lambda = kZ \dots\dots\dots(1)$$

Where λ = wavelength of radiation k = constant Z = atomic number.

ie. elements emit radiation at characteristic wavelengths. Absorption and emission occur predominantly in the first few surface layers of atoms. Suitable

correction for matrix effects, can be done by preparing standards with composition as close as possible to the sample. The intensity is proportional to the concentration of the element. Two types of instrument are used, which differ according to how the fluorescent radiation is analysed.

In wavelength-dispersive instruments, the emission at each wavelength is measured sequentially, using diffraction from a rotating crystal by directing individual wavelengths to the detector. In energy-dispersive instruments the whole of the fluorescence is measured simultaneously at the detector. The contributions from each wavelength are separated electronically. This type of instrument is more convenient and the produces analyses is more rapid , but less sensitive. Dust samples are analysed more conveniently by this technique.

Elements above atomic number 40 can be analysed by this method. By using vacuum techniques elements from F to Ca can also be analysed. Particulate samples collected on filter-paper can be analysed without pretreatment. Detection limits for elements vary widely, but for air-borne particles they are of the order of $10^{-2} \mu\text{g m}^{-3}$, when expressed as the original atmospheric concentration.

X-ray Emission by fast electron:

The bombardment of a sample with fast electrons can also generate X-rays. This technique is used in the electron microprobe analyser. The electron beam can be focused on a small area, which can be as small as an individual dust particle. This is an extremely powerful technique in the assessment of composite dust samples. It is also one of the few techniques capable of quantitative analysis of the low-mass samples produced by a cascade impactor. The instrument is also used as a conventional microscope.

Neutron activation analysis:

In neutron activation analysis, the sample is exposed to a high neutron flux to produce radionuclides of the elements of interest. As the formed radionucleus decays it emits gamma rays. The intensity of the gamma emission is measured using a scintillation counter which after correcting for detector efficiency can be correlated to the original concentration of the element in the sample.

For example in the analysis of manganese in a dust sample, the ^{55}Mn present in the sample on irradiation with neutrons, produces ^{56}Mn which decays to give gamma rays, the intensity of which can be correlated to the manganese concentration.

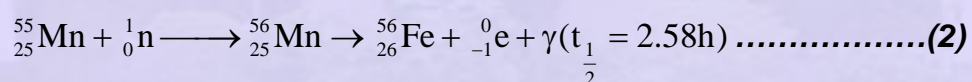

The weight of a given element present in a sample is usually determined by a comparison technique. A known amount of the element of interest is bombarded simultaneously with the test sample and is processed, after its activation, in the same manner as the test sample. Using the following relation $[W(\text{test})/W(\text{comparator})=A(\text{test})/A(\text{comparator})]$. where $W(\text{test})$ is the weight of test sample taken, $W(\text{comparator})$ is the weight of the standard, $A(\text{test})$ is the activity of the test sample and $A(\text{comparator})$ activity of the standard and knowing all the values which are obtained experimentally except $W(\text{test})$, i.e the weight of the test sample can be calculated. When more than one element is activated, the components have to be isolated by chemical separation procedures or be separated on the basis of the energy of the different emissions. As little as $0.1\mu\text{g}$ of the sample only is needed for the analysis and the technique

is very sensitive. Detection limits for the air borne particulates can be as low as $2 \times 10^{-5} \mu\text{g m}^{-3}$. The major drawback of this technique is that it requires a nuclear reactor for the neutron source.

Infrared spectrometry:

This technique is used for compounds which have characteristic absorption frequencies well away from those of likely interfering components. Quartz may be determined by this method using absorption at 780 and 800 cm^{-1} . The sample is introduced into the beam either directly on the filter-paper or after making a pressed disc by grinding the sample with potassium bromide and compressing under high pressure. The absorptions are compared with standards produced from atmospheres containing known quantities of quartz of similar particle size to that of the sample.

Drawbacks of the direct analysis:

Though the direct analysis without dissolution of particulates appear to offer many advantages over methods requiring sample dissolution there are disadvantages which sometimes restrict their use.

Even in the direct analysis sample preparation is required for preparing calibration curves and for the analysis of small number of samples the time saved is not much. In the analyses of large samples, the sample analysed which is of a few milligrams has to be representative of the whole sample. Since the techniques like X-ray fluorescence respond to only a few layers of atom within the sample due care must be taken in not getting misleading results since surface layers must have a different composition from that of the bulk.