

9.4 Transition in Field Example

Problem:

Malaprabha Project transition at entry to tunnel and exit from tunnel

Tunnel: Approach cut 1280.16 m long

Slope (bed) 1:2700, $y = 5.4864$ m

Side slope 1:1

$b = 6.096$ m, velocity = 1.794 ms^{-1}

Horse shoe shape Tunnel length 4620.77 m

Bed Slope 1: 1230

Tunnel

Diameter 6.0198 m

Velocity 2.384 m/s

Exit $b = 6.096$ m

Depth = 4.2672 m

Velocity = 1.453 m/s

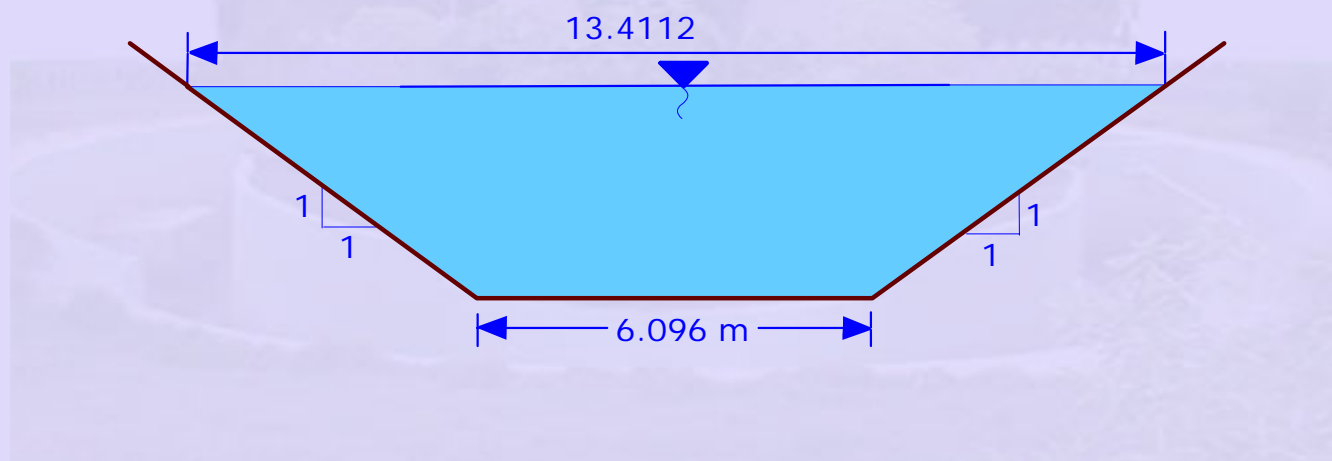

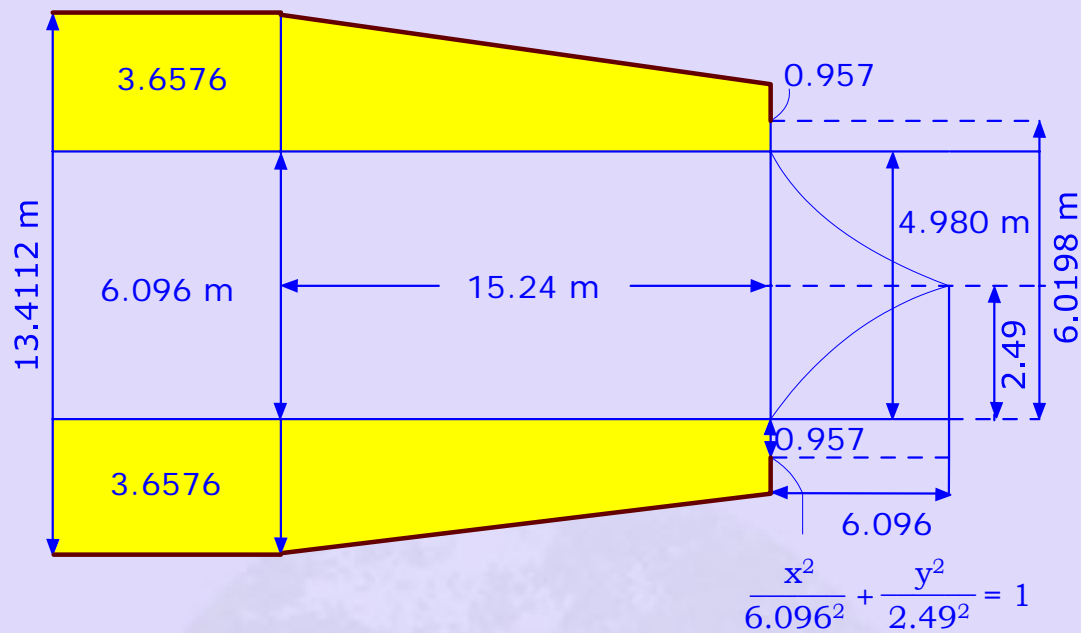

Plan of transition - Trapezoidal to Horse shoe Tunnel

$$\frac{x^2}{37.1612} + \frac{y^2}{6.2001} = 1$$

$$d_o = 6.0198 \text{ m}$$

$$\frac{d_o}{2} = 3.099 \text{ m}$$

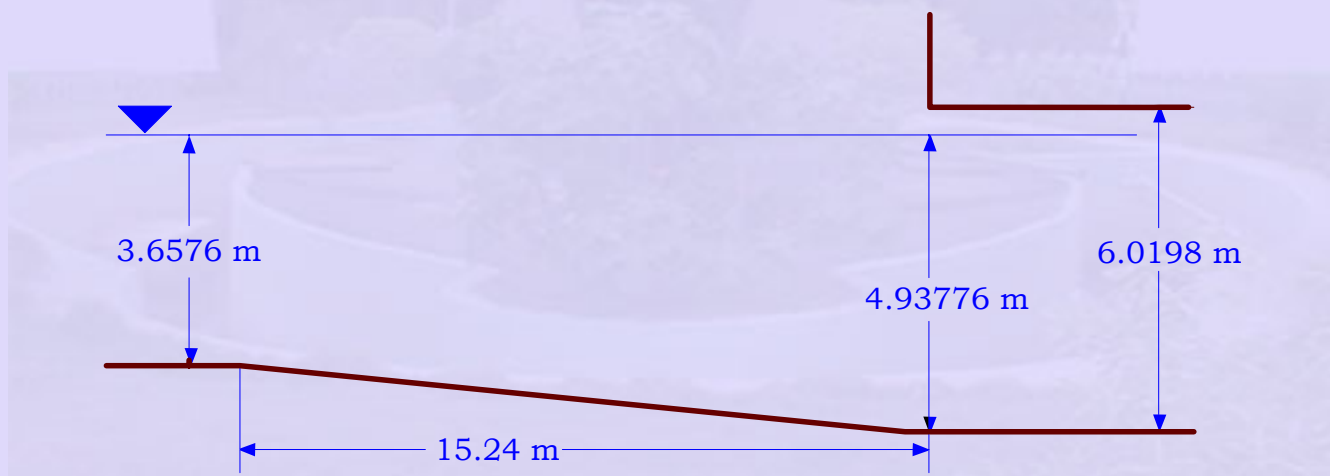

Design Discharge = 62.297 m³/s
 n = 0.018

