

8.2 Continuous Beams (Part I)

This section covers the following topics.

- Analysis
- Incorporation of Moment due to Reactions
- Pressure Line due to Prestressing Force

Introduction

Beams are made continuous over the supports to increase structural integrity. A continuous beam provides an alternate load path in the case of failure at a section. In regions with high seismic risk, continuous beams and frames are preferred in buildings and bridges. A continuous beam is a statically indeterminate structure.

The advantages of a continuous beam as compared to a simply supported beam are as follows.

- 1) For the same span and section, vertical load capacity is more.
- 2) Mid span deflection is less.
- 3) The depth at a section can be less than a simply supported beam for the same span. Else, for the same depth the span can be more than a simply supported beam.
⇒ The continuous beam is economical in material.
- 4) There is redundancy in load path.
⇒ Possibility of formation of hinges in case of an extreme event.
- 5) Requires less number of anchorages of tendons.
- 6) For bridges, the number of deck joints and bearings are reduced.
⇒ Reduced maintenance

There are of course several disadvantages of a continuous beam as compared to a simply supported beam.

- 1) Difficult analysis and design procedures.
- 2) Difficulties in construction, especially for precast members.
- 3) Increased frictional loss due to changes of curvature in the tendon profile.
- 4) Increased shortening of beam, leading to lateral force on the supporting columns.
- 5) Secondary stresses develop due to time dependent effects like creep and shrinkage, settlement of support and variation of temperature.

- 6) The concurrence of maximum moment and shear near the supports needs proper detailing of reinforcement.
- 7) Reversal of moments due to seismic force requires proper analysis and design.

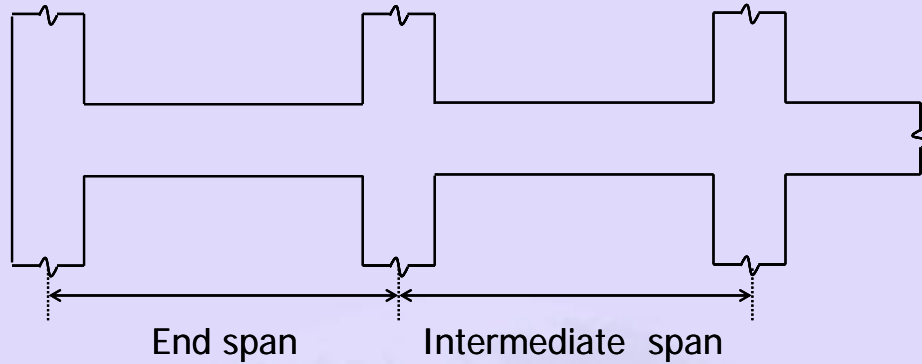

(a) Continuous beam in a building frame

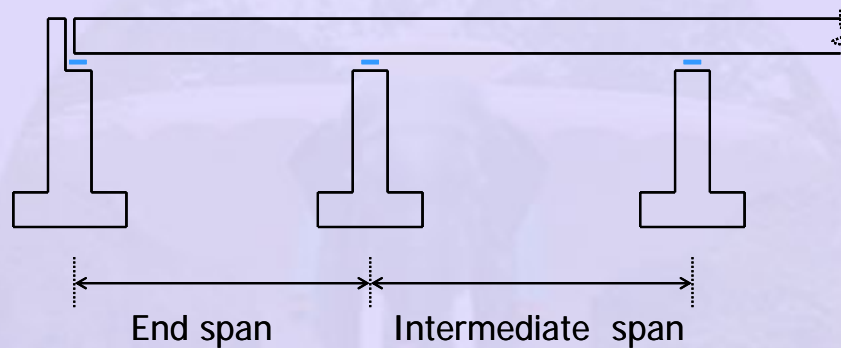

(b) Continuous beam in a bridge

Figure 8-2.1 Continuous beams in buildings and bridges

8.2.1 Analysis

The analysis of continuous beams is based on elastic theory. This is covered in text books of structural analysis. For prestressed beams the following aspects are important.

- 1) Certain portions of a span are subjected to both positive and negative moments. These moments are obtained from the envelop moment diagram.
- 2) The beam may be subjected to partial loading and point loading. The envelop moment diagrams are developed from “**pattern loading**”. The pattern loading refers to the placement of live loads in patches only at the locations with positive or negative values of the **influence line diagram** for a moment at a particular location.
- 3) For continuous beams, prestressing generates reactions at the supports. These reactions cause additional moments along the length of a beam.

The analysis of a continuous beam is illustrated to highlight the aspects stated earlier. The bending moment diagrams for the following load cases are shown schematically in the following figures.

- 1) Dead load (DL)
- 2) Live load (LL) on every span
- 3) Live load on a single span.

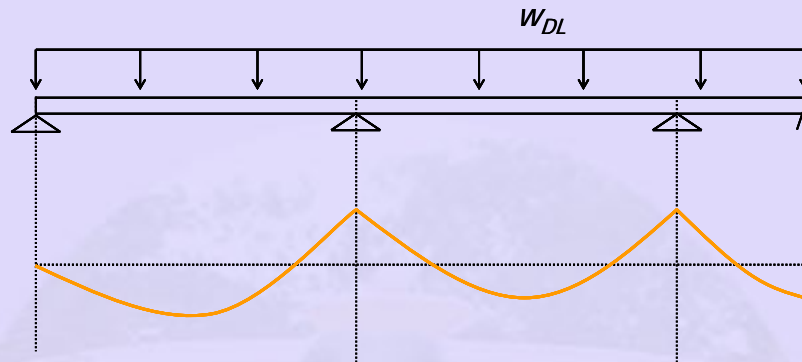

Moment diagram for DL

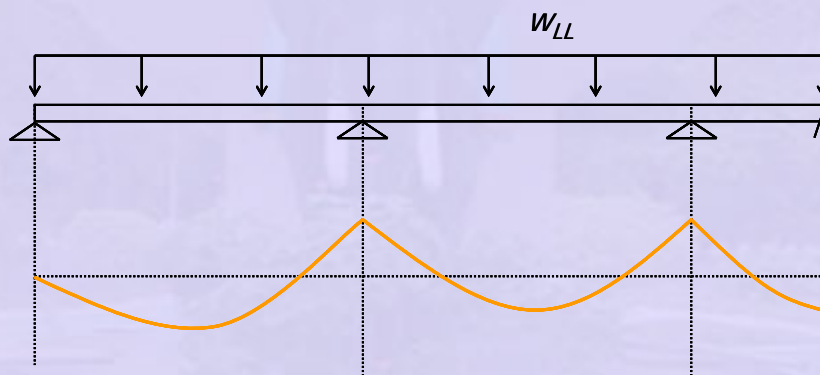

Moment diagram for LL on every span

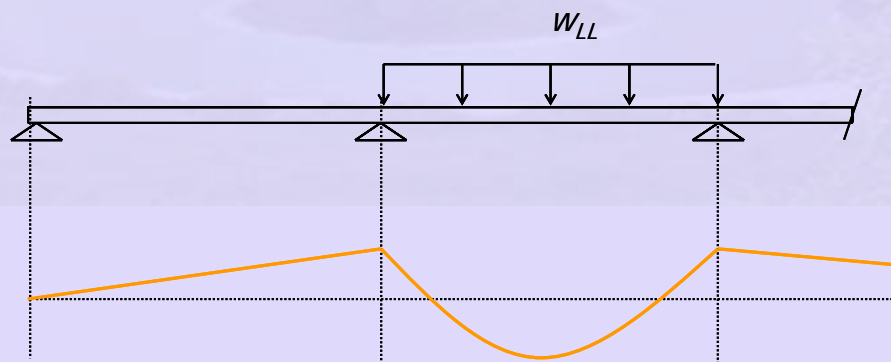

Moment diagram for LL on one span

Figure 8-2.2 Moment diagrams for dead and live loads

For moving point loads as in bridges, first the influence line diagram is drawn. The influence line diagram shows the variation of the moment or shear for a particular location in the girder, due to the variation of the position of a unit point load. The vehicle load is placed based on the influence line diagram to get the worst effect. An influence line diagram is obtained by the **Müller-Breslau Principle**. This is covered in text books of structural analysis.

IS:456 - 2000, Clause 22.4.1, recommends the placement of live load as follows.

- 1) LL in all the spans.
- 2) LL in adjacent spans of a support for the support moment. The effect of LL in the alternate spans beyond is neglected.
- 3) LL in a span and in the alternate spans for the span moment.

The envelop moment diagrams are calculated from the analysis of each load case and their combinations. The analysis can be done by moment distribution method or by computer analysis.

In lieu of the analyses, the moment coefficients in **Table 12** of **IS:456 - 2000** can be used under conditions of uniform cross-section of the beams in the several spans, uniform loads and similar lengths of span.

The envelop moment diagrams provide the value of a moment due to the external loads. It is to be noted that the effect of prestressing force is not included in the envelop moment diagrams. The following figure shows typical envelop moment diagrams for a continuous beam.

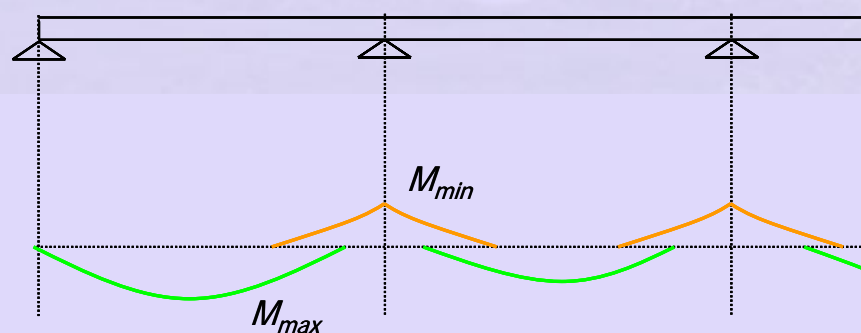

Figure 8-2.3 Envelop moment diagrams for DL + LL

In the above diagrams, M_{max} and M_{min} represent the highest and lowest values (algebraic values with sign) of the moments at a section, respectively. Note that certain portions of the beam are subjected to both positive and negative moments. The moment from the envelop moment diagrams will be represented as the **M_0 diagram**. This diagram does not depend on whether the beam is prestressed or not.

8.2.2 Incorporation of Moment Due to Reactions

As mentioned before, for continuous beams prestressing generates reactions at the supports. The reactions at the intermediate supports cause moment at a section of the continuous beam. This moment is linear between the supports and is in addition to the moment due to the eccentricity of the prestressing force. The concept is explained by a simple hypothetical two-span beam in the following figure. The beam is prestressed with a parabolic tendon in each span, with zero eccentricity of the CGS at the supports.

The moment diagram due to the eccentricity of the prestressing force and neglecting the intermediate support is denoted as the **M_1 diagram**. This diagram is obtained as $M_1 = Pe$, where, P is the prestressing force (P_0 at transfer and P_e at service) and e is the eccentricity of the CGS with respect to CGC. Neglecting the variation of P along the length due to frictional losses, the value of M_1 is proportional to e . Hence, the shape of the M_1 diagram is similar to the cable profile.

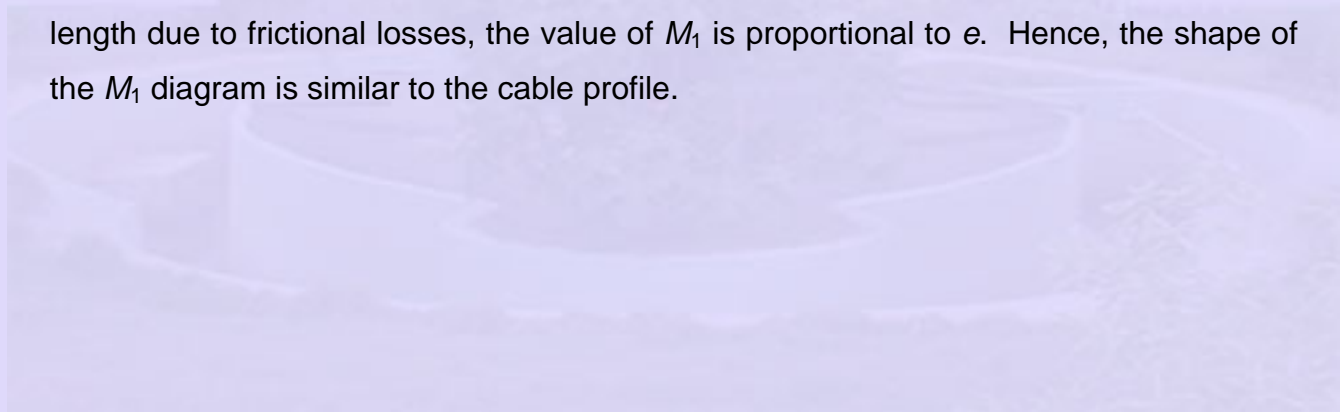

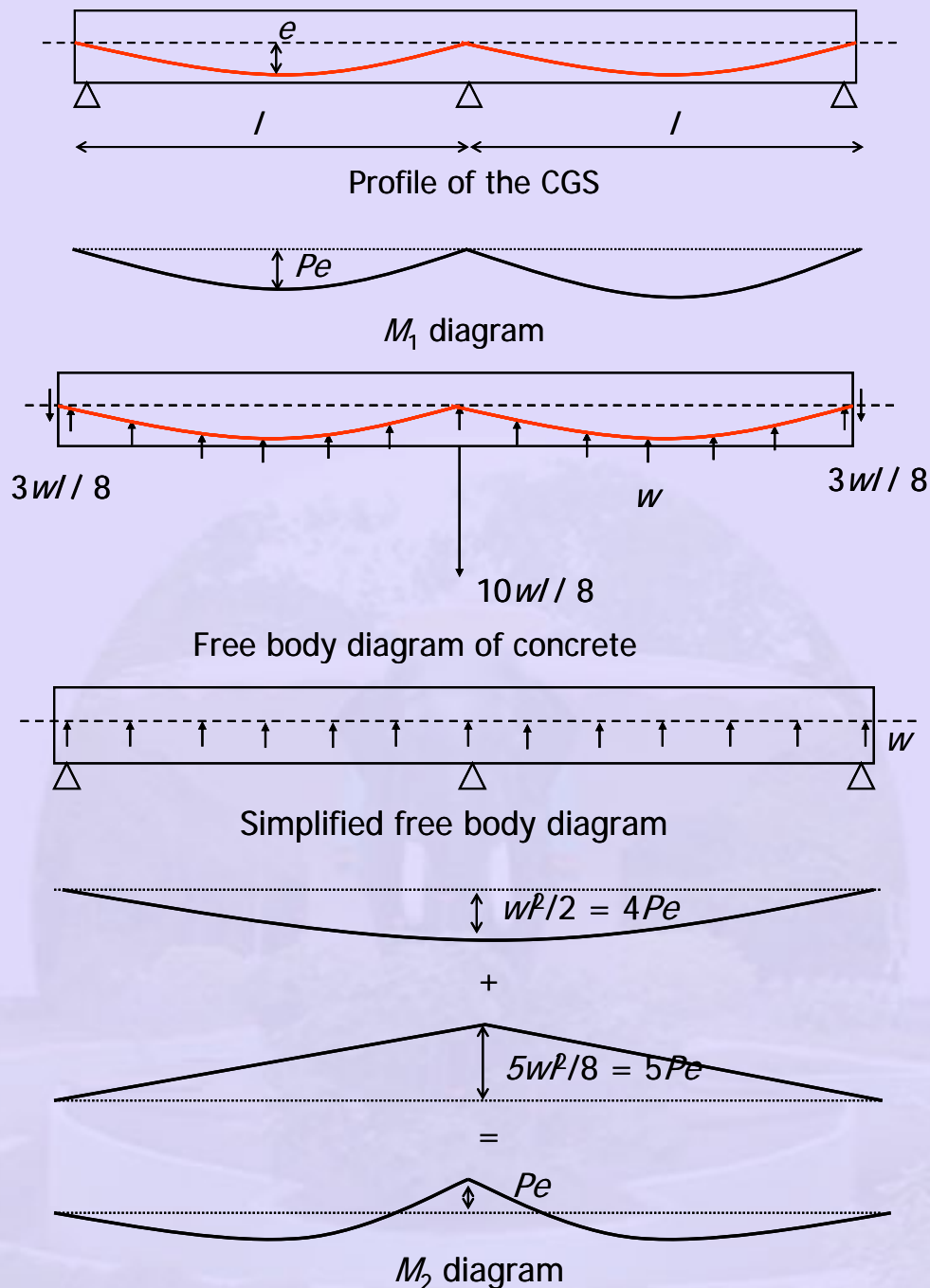

Figure 8-2.4 Moment diagram due to prestressing force for a two-span beam

Next, the moment diagram due to the prestressing force and including the effect of the intermediate support is denoted as the **M_2 diagram**. This is obtained by structural analysis of the continuous beam subjected to the upward thrust. Since the profile of the tendon is parabolic in each span, the upward thrust is uniform and is given as $w_{up} = w = 8Pe/l^2$. The downward thrust at the location of the central kink is not considered as it directly goes to the intermediate support. The hold down force at the intermediate support neglecting the downward thrust is $10w_{up}l/8 = 10Pe/l$. The downward forces at the ends are from the anchorages. The moment diagram due to w_{up} alone (without the

support) is added to that due to the hold down force. The resultant M_2 diagram is similar to the previous M_1 diagram, but shifted linearly from an end support to the intermediate support.

For a general case, the resultant moment (M_2) at a location due to the prestressing force can be written as follows.

$$M_2 = M_1 + M_1' \quad (8-2.1)$$

In the above equation,

M_1 = moment due to the eccentricity of the prestressing force neglecting the intermediate supports

$$= P_e e.$$

M_1' = moment due to the reactions at intermediate supports.

P_e = effective prestress

e = eccentricity of CGS with respect to CGC.

M_1 is the **primary moment** and M_1' is the **secondary moment**.

The moment due to the external loads (M_0) that is obtained from the envelop moment diagrams is added to M_2 to get the resultant moment (M_3) at a location.

$$M_3 = M_2 + M_0$$

$$M_3 = M_1 + M_1' + M_0 \quad (8-2.2)$$

The variation of M_3 along the length of the beam (**M_3 diagram**) can be calculated as follows.

- 1) The M_0 diagram is available from the envelop moment diagram.
- 2) Plot M_1 diagram which is similar to the profile of the CGS. The variation of P_e along the length due to friction may be neglected.
- 3) Plot the shear force (V) diagram corresponding to the M_1 diagram from the relationship $V = dM_1/dx$.
- 4) Plot the equivalent load (w_{eq}) diagram corresponding to the V diagram from the relationship $w_{eq} = dV/dx$. Note, over the supports w_{eq} can be downwards. Also, a singular moment needs to be included at an end when the eccentricity of the CGS is not zero at the end.

- 5) Calculate the values of M_2 for the continuous beam (with the intermediate supports) subjected to w_{eq} using a method of elastic analysis (for example, moment distribution or computer analysis). Plot the M_2 diagram.
- 6) The M_3 diagram can be calculated by adding the values of M_2 and M_0 diagrams along the length of the beam.

The following figures explain the steps of developing the M_2 diagram for a given profile of the CGS and a value of P_e .

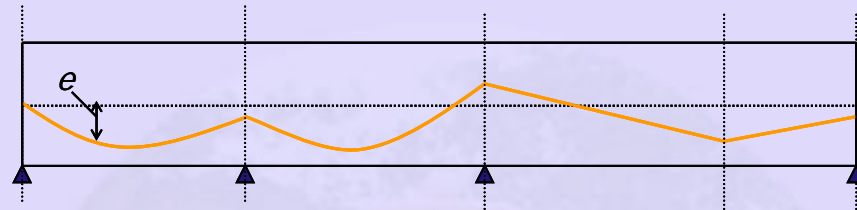

Given profile of the CGS

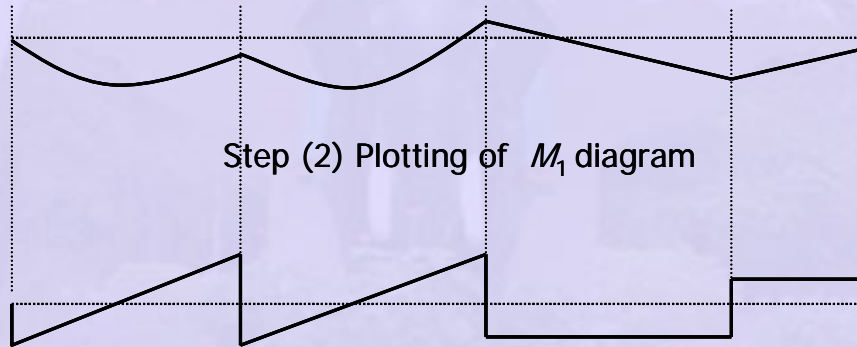

Step (2) Plotting of M_1 diagram

Step (3) Plotting of V diagram

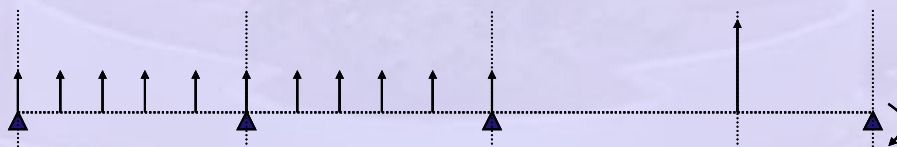

Step (4) Plotting of w_{eq} diagram

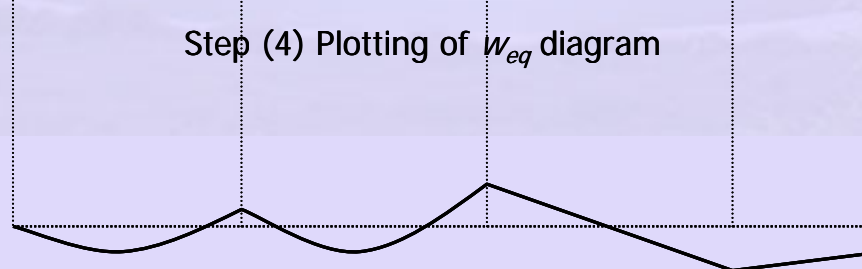

Step (5) Plotting of M_2 diagram

Figure 8-2.5 Development of the moment diagram due to prestressing force

The important characteristics of the diagrams are as follows.

- 1) A positive eccentricity of the CGS creates a negative moment (M_1) and an upward thrust.
- 2) The M_2 diagram has a similar shape to the M_1 diagram, which is again similar to the profile of the CGS. This is because the moment generated due to the reactions (M_1') is linear between the supports.

8.2.3 Pressure Line due to Prestressing Force

The pressure line (thrust line or *C*-line) **due to the prestressing force only** can be determined from the M_2 diagram. It is to be noted that the external loads are not considered in this pressure line. This is used to select the profile of the CGS.

The calculation of pressure line from the M_2 diagram is based on the following expression. The pressure line can be plotted for the different values of M_2 along the length.

$$e_c = M_2 / P_e \quad (8-2.3)$$

Here,

e_c = distance of the pressure line from the CGC at a location. A positive value of e_c corresponds to a hogging value of M_2 and implies that the pressure line is beneath the CGC.

The following sketch shows the pressure line for a given profile of the CGS.

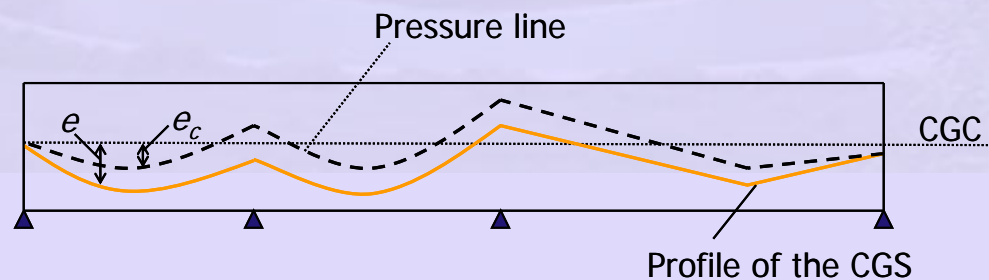

Figure 8-2.7 Pressure line for a continuous beam

The important characteristics of the pressure line are as follows.

- 1) The shift of the pressure line from the profile of the CGS is a linear transformation. It is because M_2 diagram has a similar shape to the profile of the CGS.

- ⇒ The pressure line will have the same intrinsic shape as the profile of the CGS.
- 2) Since M_2 is proportional to the prestressing force, the eccentricity of the pressure line (e_c) remains constant even when the prestressing force drops from the initial value P_0 to the effective value P_e .
- ⇒ The location of the pressure line for a given profile of the CGS is fixed, irrespective of the drop in the prestressing force.

Example 8-2.1

The profile of the CGS for a post-tensioned beam is shown in the sketch. Plot the pressure line due to a prestressing force $P_e = 1112$ kN.

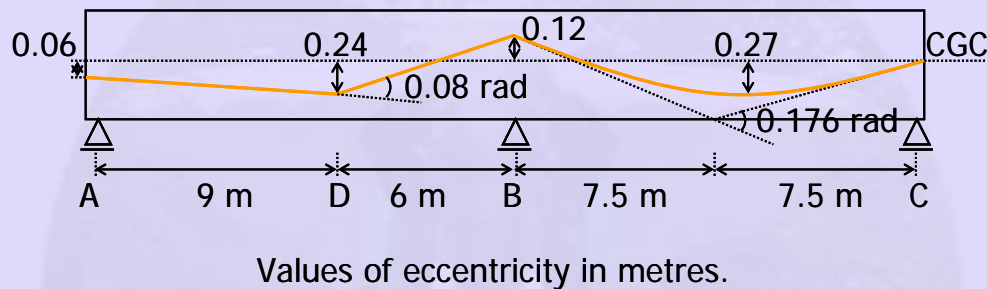

Solution

1) Plot M_1 diagram

The values of M_1 are calculated from $M_1 = P_e e$.

e (m)	M_1 (kN m)
0.06	- 66.7
0.24	- 266.9
- 0.12	133.4
0.27	- 300.2

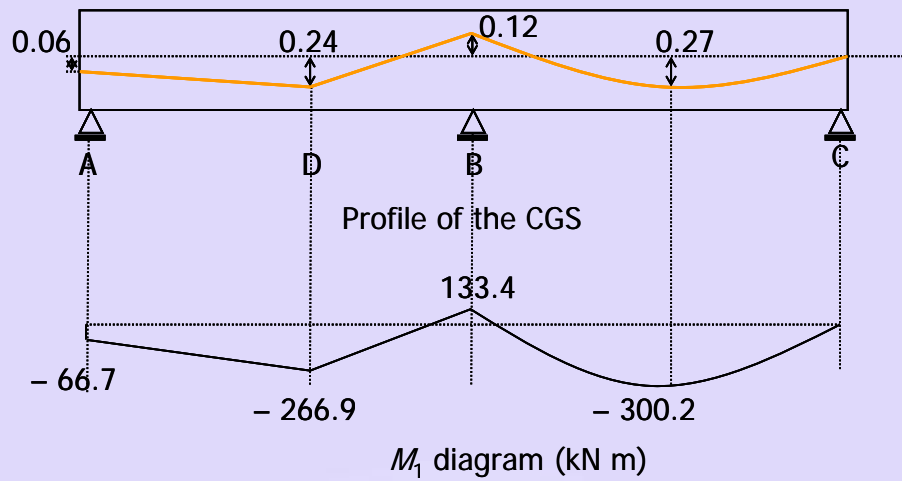

2) Plot V diagram

For AD,

$$\begin{aligned} V &= \frac{dM_1}{dx} \\ &= \frac{-266.9 - (-66.7)}{9} \\ &= -22.2 \text{ kN} \end{aligned}$$

For DB,

$$\begin{aligned} V &= \frac{dM_1}{dx} \\ &= \frac{133.4 - (-266.9)}{6} \\ &= 66.7 \text{ kN} \end{aligned}$$

For BC, to find dM_1/dx , an approximate parabolic equation for the M_1 diagram can be used.

$$\begin{aligned} M_1 &= -\frac{4P_e e x}{L^2} (L - x) \\ V &= \frac{dM_1}{dx} \\ &= -\frac{4P_e e}{L^2} (L - 2x) \end{aligned}$$

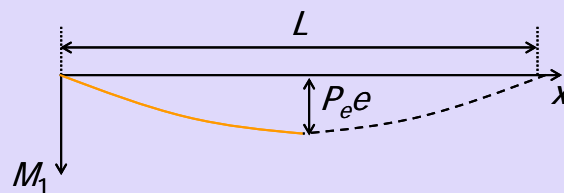

At B,

$$\begin{aligned} V &= \left. \frac{dM_1}{dx} \right|_{x=0} \\ &= -\frac{4P_e e}{L} \\ &= -\frac{4 \times (133.4 + 300.2)}{15} \\ &= -115.6 \text{ kN} \end{aligned}$$

The exact value of V at B is

$$V = -107.0 \text{ kN}$$

The difference of V between C and B is given from the change in slope of the M_1 diagram.

$$\begin{aligned} V|_C - V|_B &= 0.176 \times 1112 \\ &= 195.7 \text{ kN} \end{aligned}$$

Therefore, value of V at C is given as follows.

$$\begin{aligned} V|_C &= 195.7 - 107.0 \\ &= 89.0 \text{ kN} \end{aligned}$$

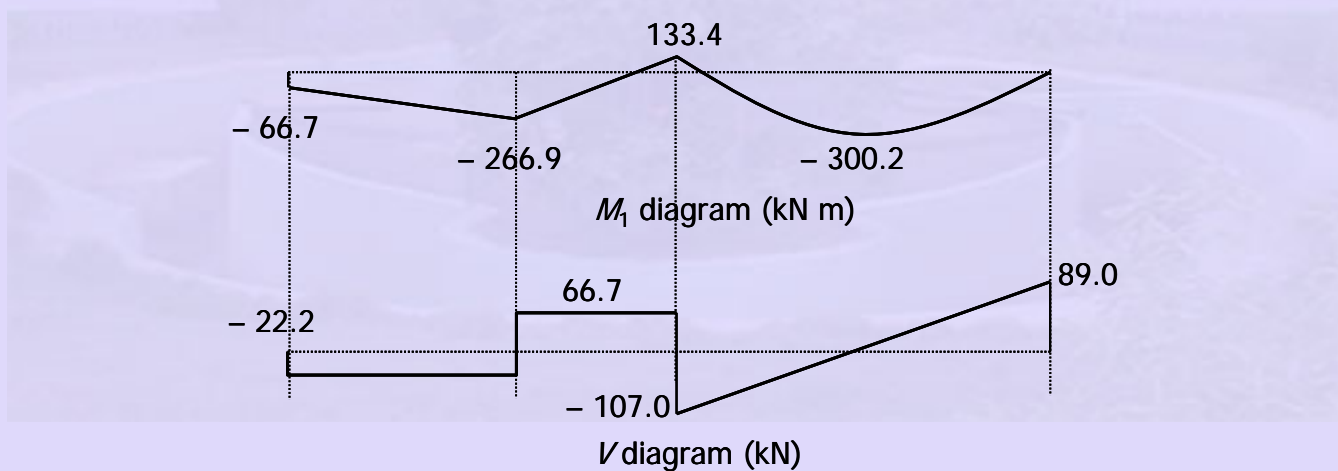

3) Plot equivalent load (w_{eq}) diagram

Include moment 66.7 kN-m at A.

Point load at D

$$\begin{aligned} W|_D &= 66.7 - (-22.2) \\ &= 88.9 \text{ kN} \end{aligned}$$

Since B is a reaction point, the downward load at B need not be considered.

Distributed load within B and C

$$w_{BC} = \frac{89.0 - (-107.0)}{15}$$

$$= 13.0 \text{ kN/m}$$

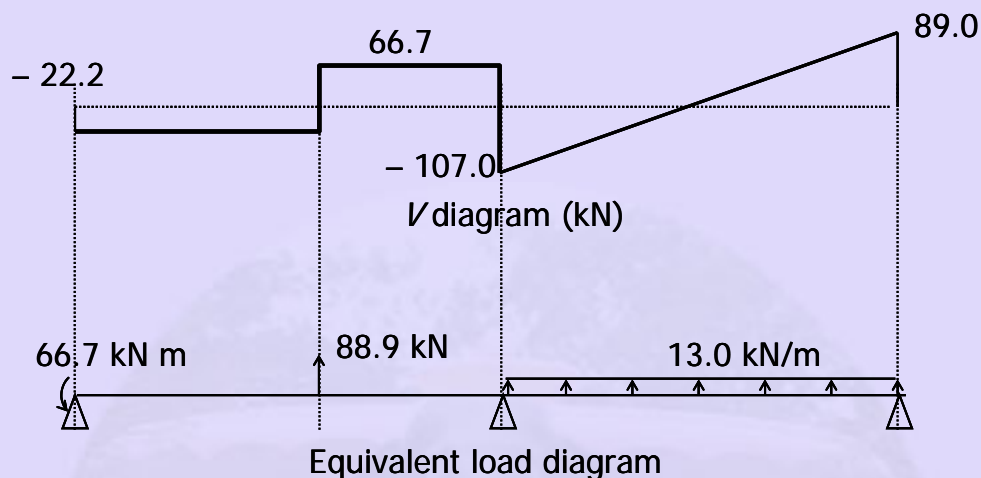

4) Plot the M_2 diagram.

Calculate moment at supports by moment distribution

	66.7	88.9	13.0	
DF		0.5	0.5	
FEM	$\frac{88.9 \times 9 \times 6^2}{15^2}$	$\frac{88.9 \times 9^2 \times 6}{15^2}$	$\frac{13.0 \times 15^2}{12}$	
	= 128)	= -192 (= 244)	(-244
Bal	-194.7			244
CO		-97	122	
Bal		-38.5	-38.5	
Total	-66.7	-327.5	327.5	0

In the previous table,

- Bal = Balanced
- CO = Carry Over moment
- DF = Distribution Factor
- FEM = Fixed End Moment.

The moment at the spans can be determined from statics. But this is not necessary as will be evident later.

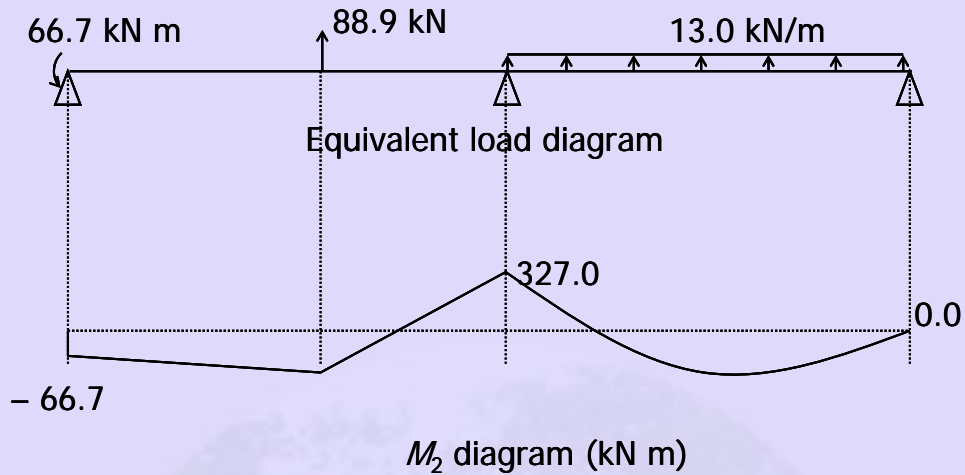

5) Calculate values of e_c at support.

The values of e_c are calculated from $e_c = M_2/P_e$.

M_2 (kN m)	e_c (m)
- 66.7	0.06
327.0	0.294
0.0	0.184

The deviations of the pressure line from the CGS at the spans can be calculated by linear interpolation.

